

*Small Wonder Labs*  
**'Retro-75' AM Transceiver**  
Board Kit Instructions

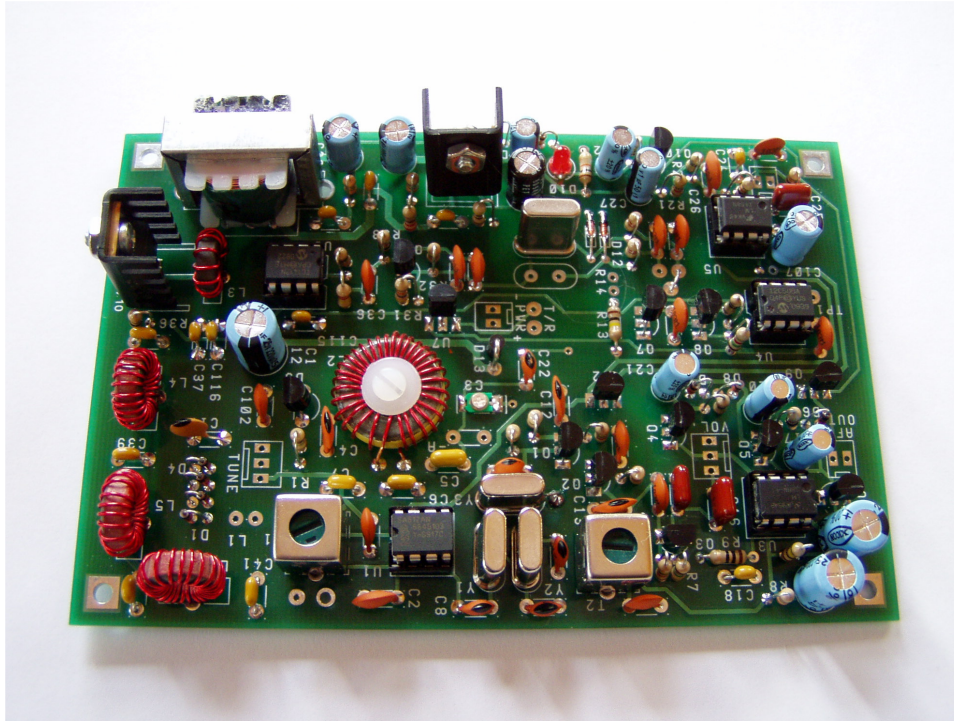

*For illustrative purposes only- do not use as a reference.*

***Thanks for purchasing a Small Wonder Labs "Retro-75" transceiver kit!***

Please take a few moments to look over the sections entitled "*First Things First*" before you dive in. This section contains information which is key to your success with this kit.

TABLE OF CONTENTS:

Tools/Basic Info	2,3
Component Identification	4
Retro -75 Description	5,6
Parts List	7, 8
Schematics	9-10
Pictorial Drawing	11
Building instructions	12
Wiring Up the 'Retro-75'	14
Alignment	15-16
Troubleshooting the "Retro-75" [under construction]	

#### THE FINE PRINT:

There are lots of small parts in this kit. I strongly recommend a magnifying glass or close-up glasses to check all solder joints and component codes.

#### THE OTHER FINE PRINT:

If you encounter conflicts between various sections of this document, contact me for a resolution. The following order of precedence applies:

- Schematic (most trustworthy)
- Parts list
- Pictorial

#### TOOLS:

You'll need the following tools:

- Soldering iron- ~25W
- 60/40 solder, small diameter
- Diagonal cutters
- Needle-nose pliers
- Small slot screwdriver

#### TEST EQUIPMENT:

- Multimeter
- 50-ohm dummy load

#### RETRO-75 Power Requirements.

The RETRO-75 is designed to operate with a minimum supply voltage of approximately 10V. A power supply capable of delivering a minimum of 1 Amp at 12-14 Volts DC is recommended. Maximum recommended supply voltage is 16VDC.

I use the Radio Shack 13.8V 3A bench supply, it's their part number **22-507**. Jameco Electronics ([www.jameco.com](http://www.jameco.com)) has inexpensive wall-wart supplies, but users have reported switcher noise on some of them. **Note: the less expensive ones are unregulated and will not provide adequately filtered DC- don't waste your money! 'Filtered' is not sufficient- you need to see the word 'Regulated' on the description.**

#### FIRST THINGS FIRST --*Stuff worth knowing!*

##### COLOR CODES:

Resistor color codes are given in the parts list. Radio Shack's Color-Code Guide, #271-1210, or the ARRL Handbook will help. If you're not sure, verify the resistor values with a multimeter before installing.

For what it's worth, roughly 8% of the male population is red/green color-blind. If you're one of these, you should be verifying all resistors with a multimeter before installing them.

The RETRO-75 board is double-sided and all holes on the board are plated-through. This means that you do not need to solder on the top side of the board.

##### SOLDERING SKILLS

Hopefully this isn't your first experience with a soldering iron. If it is, though, or this is your first solid-state project, here are some tips to ensure your success:

- Soldering Iron:

Use a small iron in the 25-watt class (such as a Radio Shack #64-2070) and keep the tip clean. Use a moistened sponge or paper towel to clean the tip periodically as you work.

Apply only as much heat as is needed to get a good joint. A small vise to hold the printed-circuit board may make soldering easier.

Touch the soldering iron tip to the PC board trace and the component lead simultaneously. Within a second or two, apply solder and you'll see the solder flow onto the junction. Withdraw the solder and then the soldering iron.

Avoid the temptation to load solder onto the joint until no more will fit! This is an invitation for trouble, as solder bridges may form across the closer trace separations. Here's what the correct and incorrect joint treatments look like:

SOLDER FILLET IS CONCAVE AND 'WETS'  
SMOOTHLY TO COMPONENT LEAD

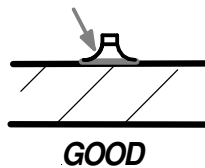

SOLDER FILLET IS CONVEX OR DOES NOT  
ADHERE TO COMPONENT LEAD

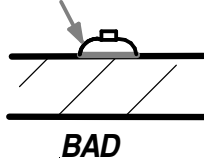

PLEASE READ THE SECTION BELOW  
BEFORE REMOVING ANY PARTS FROM THE  
BOARD

Uh-oh! Sooner or later, you may need to remove a part installed in the wrong location, or perhaps pull a component for troubleshooting purposes.

Get yourself a roll of desoldering braid (Radio Shack #64-2090B). Lay the end of the braid down on the joint to be cleaned and press the soldering iron tip over the braid. Within several seconds you'll see the braid begin to wick up solder from the joint. Remove the braid and reapply a new section as needed until the joint is clean. It may be necessary to pull the component out from the top side of the board while heating the joint. Leave the iron tip on the board only as long as necessary to do the job- the PC-board traces will eventually delaminate (peel off) if overheated.

If that still doesn't do the job, it may be necessary to cut the offending part off on the top side and pull the remaining leads through with pliers.

If you need to remove a transistor, I'd highly recommend sacrificing the part by snipping it off on the top side of the board. The leads are best pulled out singly to minimize the risk of lifting pads. Contact me for replacement parts if necessary.

After removing a component from the board, the through-hole will probably still be blocked with solder. Use a dissecting needle or dental probe (explorer), apply heat to the probe and the board trace simultaneously until the tool pushes through. Lacking either of these tools, a round wooden toothpick works well also!

### WINDING TOROIDS:

-Count as you go. Draw each turn snug against the core to ensure a trim and tight winding

-Double-check the turns count when you're finished. Use your fingernail or small screwdriver to "bump" over each turn as you count- this is easier than counting by eye.

- Trim the excess wire off to about 3/8" (1cm) and **thoroughly** strip the insulation off the ends with a knife-edge. **Do not count on the heat from a soldering iron to melt the insulation!**

Counting the turns:

**If the wire passes through the toroid center hole, it counts as a turn.** *Here's an example:*

*This toroid is wound with 8 turns*

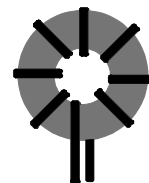

- Turns must be uniformly distributed around the circumference of the toroid.

### MATERIALS-

You'll find the following items with your Retro-75 kit:

- 1- bag of parts, miscellaneous
- 1- antistatic bag (contains semiconductors)
- 1- poly bag (resistors/capacitors)
- 1- printed circuit board
- (these instructions )

## REFERENCE DESIGNATORS:

Each component is uniquely identified with a reference designator. Bypass capacitors are identified as C101 and up. Reference designators are shown in blue on the schematic pages. Component values are shown in magenta.

## COMPONENT IDENTIFICATION:

- Resistors and RF chokes

This manual describes the color coding for all resistors. Only the first three bands are described, the fourth band is a tolerance code, typically gold (=5%) and is not listed. All resistors are 1/4W 5% carbon film types, RF chokes are also an axial (leads on each end) component but are shaped differently.

- Capacitors:

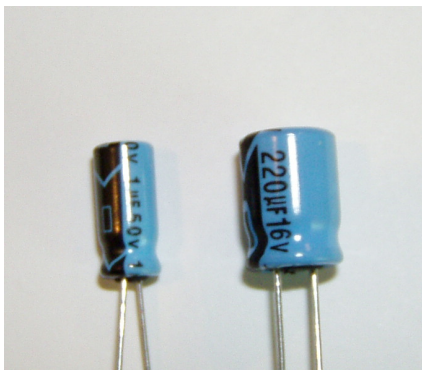

Electrolytic caps. The black band denotes the negative end of the capacitor.

- NPO Disk Caps

NPO disk caps may be distinguished from other types of disk caps- they have a black band at the tip of the ceramic disk.

- Extra information on components

There's often extraneous information marked on components. Examining a sample IC, I find "MC1458P1 KKJK 8949". You care only about the '1458' or other markings I've specified *If I've specified a capacitor '104' and you find the correct number of parts, but marked "104M", for instance, those are them!*

Here's the general rule for capacitor nomenclature:

If 3 digits are printed on the capacitor, the first two are significant figures and the third is a multiplier.

Examples:

$$'471' = 47 \times 10^1 = 470 \text{ pF}$$

$$'103' = 10 \times 10^3 = 10,000 \text{ pF} = .01 \text{ uF}$$

Letter suffixes: J=5%, K=10%, M=20%.

*Please: If you're looking for a '104' monolithic cap, be sure to inspect both sides of the caps before concluding we gave you the wrong value!*



Monolithic caps.

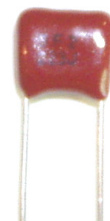

Poly Cap



D5- MV1662 Diode

## 'Retro-75 ' Description

### Inspirations:

I've long been intrigued by relatively simple voice radios. The BC-611/SCR-536 [at right] was widely used during WW II as a platoon-level radio. It had a 'bare-bones' crystal-controlled superhet receiver and an AM transmitter with 350 milliwatts of output power. It had an effective range of about a mile with its built-in whip antenna. Although pressed into service in the postwar years by enterprising hams, its lack of selectivity limited its usefulness under crowded band conditions. As I extrapolated from this radio's highly inefficient whip antenna to a full-sized dipole, I realized that the effective range would be upwards of 50 miles. In my book, that's a usable communications distance for keeping in touch with friends! That served as a challenge and as the inspiration for this project.

Although AM has long been supplanted by more effective modes of communication, AM activity is largely channelized into 'watering hole' frequencies. See [www.AMwindow.org](http://www.AMwindow.org). It's therefore pretty easy to find activity on the air. Here in the Northeast, 3885 kHz is the 'hot spot', and 3870 kHz is similarly used on the West coast.



courtesy of N6GCE  
[www.prc68.com](http://www.prc68.com)

### Receiver:

The receiver front end is entirely conventional. A series L-C T-R switch and bandpass transformer feed the SA612 first mixer. The SA612's internal oscillator is used to save component count by eliminating the need for a separate local oscillator (LO) transistor. The varicap diode-tuned LO covers about 50 kHz of the 75M band. It operates at approximately 2.1 MHz and the 1<sup>st</sup> mixer up-converts to the Intermediate Frequency (IF).

In the interest of tradition, I initially used 455 kHz IF transformer in an IF design. A double-tuned filter using these transformers proved woefully inadequate in keeping close-by SSB stations out of the detector stage. *In light of the BC-611's lack of selectivity, this was largely a case of 'reinventing the wheel'.* Rather than wrestle with more stages of filtering or the use of ceramic filters, I reverted to a tried-and-true crystal filter. I chose an IF of 6.00 MHz to keep both the filter bandwidth and the LO frequencies reasonable. With the filter values shown on the schematic, pass bandwidth is 3.5 kHz with adequate skirt characteristics. I found it necessary to ground the case of crystal Y3 to eliminate pickup of strong AM signals from the 49M shortwave broadcast band.

The IF amplifier uses the so-called 'cascode' configuration. Although the MC1350 IC is often used here, it's been around for an uncomfortably-long number of years. Parts cost was a factor, too- the discrete cascade amp has a parts cost of about 15 cents. This amplifier is terminated by R6, whose value was chosen as a compromise between stage gain and consistently stable operation.

The following stage is a peak detector which serves to recover the modulation envelope from the received signal. Q3 is an 'infinite-impedance detector'- a JFET biased near cutoff. *I'd always wanted to say I'd used one- the phrase has a nice 'Hitchhiker's Guide' ring to it.* I found it more sensitive in practice than an unbiased 1N34 Germanium diode.

U3- an LM386, is a widely-used AF Amp IC, and provides plenty of speaker volume. The transistors around it serve several functions, Receiver audio needs to be firmly shut off during transmit. The transistor switch in series with the LM386 output is important. That IC's output voltage is dependent on supply voltage. As the power supply 'pulls' on voice peaks, it yields an unwanted feedback path to the speaker.

The audio output waveform is also peak-detected by D6 and C20 and applied back to the gate of Q4 as a form of Automatic Gain Control (AGC). Without it, nearby 'Big Gun' stations are easily capable of saturating this amplifier stage, yielding harsh-sounding clipped audio. The AGC threshold is nominally 6 volts peak-peak, depending on the individual characteristics of Q4. With this feedback path in place, even the strongest of stations sounds fairly clean in the receiver.

### Transmitter:

The RF strip consists of a crystal-controlled Colpitts oscillator, a FET-driver IC, and a MOSFET Power Amplifier stage. The PA stage runs class-C to keep the transmitter efficiency reasonably high. Generating an amplitude-modulated output is done using one of the oldest tricks in the book: the transmitter's supply voltage is varied by superimposing audio on it

through transformer T3. This is an inexpensive 48Ω:3.2Ω audio output transformer. In this application, the transformer is run 'in reverse' to step up the voltage output from U6. With no audio applied, the transmitter outputs a steady carrier. At full (100%) modulation, the PA supply voltage swings to a minimum of 0V and to a maximum of twice the nominal supply voltage.

In theory, this method is simplicity itself. When it's extended to higher power levels, though, a pitfall becomes evident. The necessary modulation transformers become rather formidable in size, and they were fondly referred to as 'Big Iron' by the AM fraternity. The more modern term is, inevitably 'Heavy Metal'. I considered heating in T3 (a maximum specified output of 475mW) to be a design constraint and elected not to push it too hard. The transmitter runs about 2W of carrier power and 6-7W peak output. I ran key-down tests of up to a half-hour duration- they showed minimal transformer warming.

The 'Big Iron' approach is still in use, but it sees action mainly in vintage equipment. The necessary transformers have largely gone the way of the hoop skirt and whale-oil lamps. More recent practice uses pulse-width (class-D) modulation to directly form a varying power supply voltage, with a resulting improvement in transmitter efficiency. Other modulation classes improve further on efficiency. The interested reader is invited to see Steve Cloutier- WA1QIX's web site' [www.classeradio.com](http://www.classeradio.com) for a treatment of the topic.

The FET driver, U8, is one of a family of devices with various peak drive-current ratings. The TC1412 can source/sink 2 Amps peak; other versions can supply up to 8 A. Its output is a 3.8 MHz square wave varying between 0V and 6V. I selected the device for its small (8-pin DIP) footprint, but other builders have used CMOS hex inverters (for instance) with all gates connected in parallel for higher drive current capability.

The choice of a microphone can often be problematic. I'd initially planned on using an HT speaker/mic to do the job, but their typical shared mic/PTT line led to considerable complexity in T/R switching and AGC 'gating'. I reverted to the classic approach - a manually-operated switch- to do the job. This is more in line with the relaxed AM 'ethos' and lends more flexibility to the choice of microphones. I settled on a Radio Shack<sup>®</sup> dynamic microphone, largely because of its modest cost and wide availability.

U6 is a 10-Watt automotive AF amplifier in a 5-pin package. This device was attractive both for its output power capability and for its 'beefy' heat sink tab. Voltage gain (40dB) and frequency response are established by the R-C networks between pins 2 and 4 of this device.

A sample of the AF Amplifier's output is peak-detected and applied back to an attenuator at the stage's input. The attenuator is formed by the series resistor between AF stages and a shunt to ground provided by Q10. The series diode, LED and turn-on voltage of Q10 provide a fairly consistent AGC threshold at about 75% modulation. The 3.3K resistor in the path is there to slow the AGC response time for 'pop-free' operation. . The AF amplifier is easily capable of overmodulating the carrier, so it was gratifying to 'close the loop' and observe its effect on modulation percentage. Transistor Q9 is turned on during receive intervals to mute the transmit audio strip.

#### **Receiver 'Test' function:**

One of the impediments to building an L-C oscillator (here used as the receiver LO) is that component tolerances make the resulting operating frequency somewhat uncertain. CW/SSB projects can usually count on a borrowed signal from a 'big rig' in the shack to locate and adjust the local oscillator to frequency. With AM, though, there's no 'beat note', and you'll probably hear an 'in-shack' AM signal everywhere you tune. The circuit block labeled 'Test' provides a built-in frequency adjustment tool. At its heart is an 8-pin microcontroller coded as a frequency discriminator. It outputs a duty-cycle modulated waveform which a digital multimeter will interpret as a DC voltage. Based on the DC reading, the builder can compensate with a 'select' capacitor to bring the oscillator on frequency. See the 'Alignment' section of these instructions for further details.

## 'Retro-75' Parts List

Qty.	Ref. Designator	Description	Identification
2	C3-A,C22	22 pF NPO disk	'22J'
1	C3	6-30 pF trimmer	green
4	C8, C9, C10, C11	33 pF NPO disk	'33J'
1	C3-B	47 pF NPO disk	'47J'
1	C3-C	68 pF NPO disk	'68J'
1	C1	82 pF NPO disk	'82J'
5	C3-D, C4,C12,C13,C36	100 pF NPO disk	'101J'
1	C3-E	120 pF NPO disk	'121J'
1	C3-F	150 pF NPO disk	'151' or '151J'
2	C34,C35	220 pF NPO disk	'221' or '221J'
2	C2, C26	330 pF disk	'331' or '331J'
2	C38,C41	560 pF COG mono.	'561'
1	C15	.001 uF mono.	'102'
2	C39,C40	1200 pF COG mono.	'122'
2	C6,C7	2200 pF COG mono.	'222'
1	C5	6800 pF COG mono.	'682J'
10	C14,C23,C101-104,106,109,C113,C114	.01 uF disk	'103M'
1	C25	.015 uF poly	'015K', yellow
1	C16	.033 uF poly	'.033J', yellow
9	C18,C24,C29,C31,C37,C108,C111,115,116	.1 uF mono.	'104'
4	C21,C27,C28,C32	1 uF electrolytic	'50 v 1 uF'
2	C17,C20	10 uF electrolytic	'35 v 10 uF'
3	C33,C107, C110	100 uF electrolytic	'16 v 100 uF'
3	C19,C105,C112	220 uF electrolytic	'25V 220 uF'
1	C30	470 uF electrolytic	'470 uF 10v'
10	D1-D4, D6-D9, D11,D12	1N4148 diode	glass body
1	D5	MV1662 varicap diode	2 leads, banded
1	D10	LED	red plastic, 2 leads
1	D13	1N5818 rectifier diode	'1N 5818'
1	L1	22 uH RF choke	red-red-blk-gold
1	L2	T68-6, add 32 turns #24 wire <i>Use 30" (75cm) of wire to wind</i>	yellow toroid, large
1	L3	FT37-61, add 10 turns #24 wire <i>Use 8" (20cm) of wire to wind</i>	dark grey toroid
2	L4, L6	T44-2, add 21 turns #24 wire <i>Use 16" (40 cm) of wire to wind</i>	red toroid
1	L5	T44-2, add 23 turns #24 wire <i>Use 16" (40 cm) of wire to wind</i>	red toroid
6	Q1,Q2,,Q7,Q8, Q10, Q11	2N4401 transistor	
1	Q3	2N5485 transistor	
4	Q4-Q6,Q9	2N7000 transistor	
1	Q12	IRF530A power transistor	
1	R26	1 ohm resistor	brn-blk-gold-gold
2	R8, R25	2.2 ohm	red-red-gold-gold
2	R9, R17	10 ohm "	brn-blk-blk-gold
2	R5, R23	47 ohm "	ylw-viol-blk-gold
1	R24	220 ohm "	red-red-brn-gold
4	R11, R14, R33, R36	1K ohm "	brn-blk-red-gold
2	R2, R16	1.5K ohm "	brn-grn-red-gold
2	R29, R30	2.2K ohm "	red-red-red-gold
1	R27	3.3K ohm "	org-org-red-gold
5	R3, R4, R6, R17-A, R21	4.7K ohm "	ylw-viol-red-gold

### **'Retro-75' Parts List (cont'd)**

3	R18, R19, R22	10K ohm "	Brn-blk-org-gold
2	R31,R32	47K ohm "	Ylw-viol-org-gold
7	R10, R12, R13, R15, R20, R28, R35	100K ohm "	Brn-blk-ylw-gold
1	R34	220K ohm "	red-red-ylw-gold
2	R1, R7	1M ohm "	Brn-blk-grn-gold
2	T1,T2	IF transformer	metal can-'42IF123'
1	T3	Audio transformer	'TU048-R'
1	U1	SA612AN IC	
2	U2, U7	78L06 voltage regulator IC	
1	U3	LM386 IC	
1	U4	12C508A IC	<i>preprogrammed</i>
1	U5	LM1458/MC1458 IC	
1	U6	TDA2003V IC	
1	U8	TC1412N IC	
3	Y1-Y3	6.000 MHz crystal	
1	Y4	3.885 MHz crystal	
1	Y5	3.880 MHz crystal	
5	-	8-pin IC socket	
2	-	4-40 x 1/4" machine screw	
2	-	4-40 nut	
2	-	Heat sink	
1	-	4-40x 1/2" nylon machine screw	
1	-	4-40 nylon nut	
1	-	4-40 nylon shoulder washer	
1	-	6' (1.8m) #24 magnet wire	

#### Revision history:

**1/13/3011 release-** changed C8-C11 from 47 pF to 33 pF to harmonize filter bandwidth with 6.00-32 IF crystals.

**6/24/2011 release-** 1) added new component, R17-A, 4.7K to right of R17. 2) grounded return on 100K resistor at base of Q10. 3) Replaced C3 (SMT Trim cap) with through-hole version.

These necessitated a change to the printed circuit-board layout, now 'K1SWL 06/11'

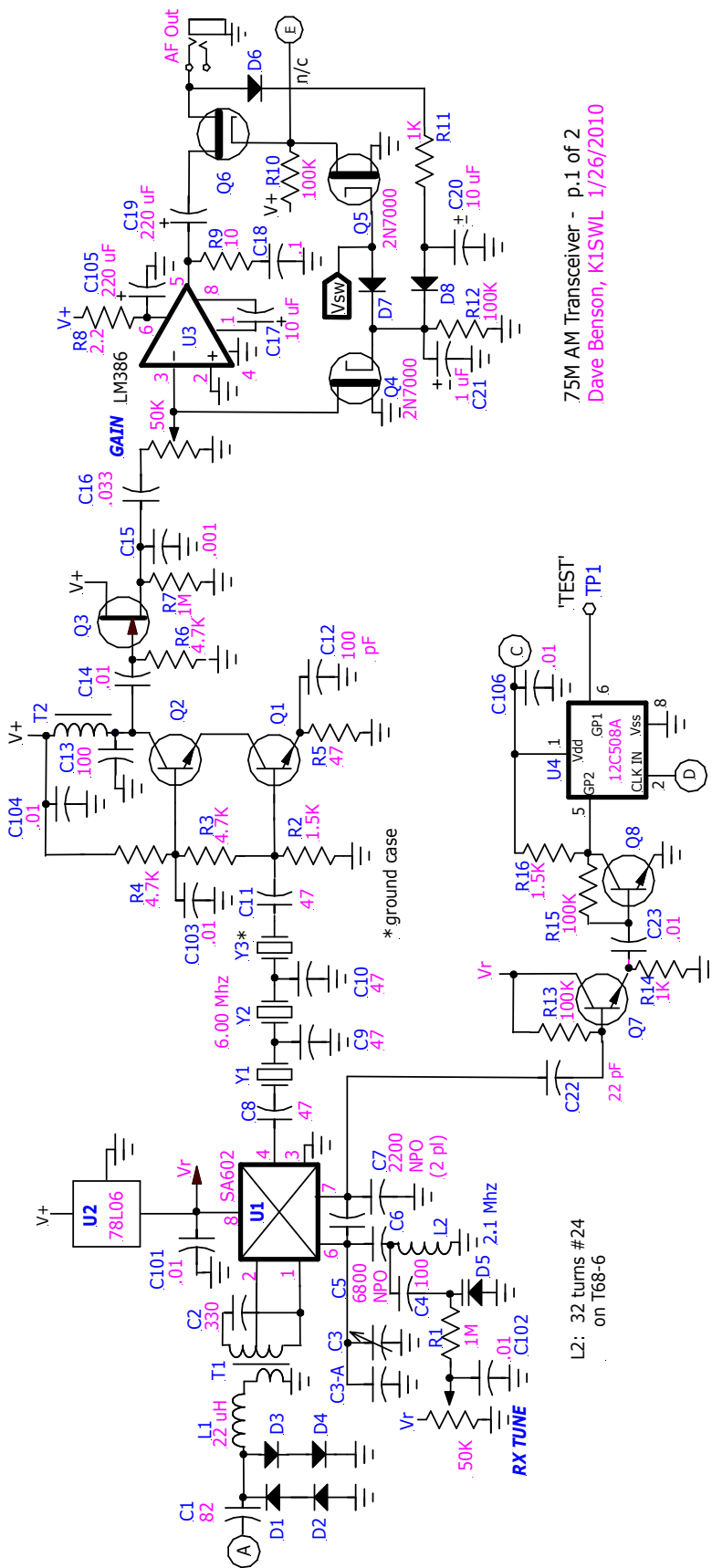

75M AM Transceiver - p.1 of 2  
 Dave Benson, K1SWL 1/26/2010

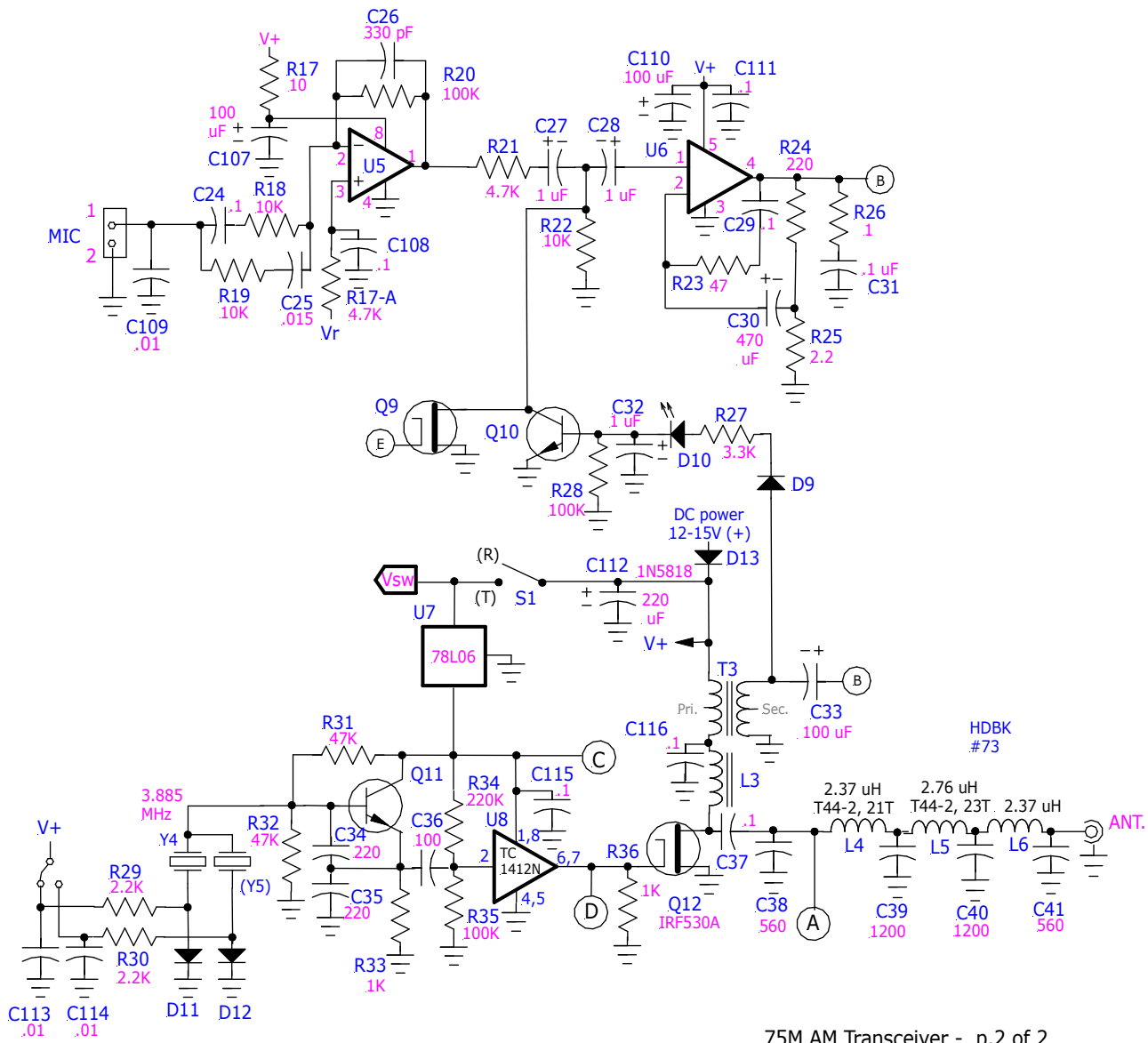

75M AM Transceiver - p.2 of 2  
 Dave Benson, K1SWL 6/24/2011



## General building instructions:

**Before you get started, it's a good idea to do an complete inventory of the parts in the kit.** Why?... so you don't discover a shortage when assembly's nearly complete. Worse yet, repeated requests for shortages discovered 'piecemeal' during building delay your progress and take time to fulfill.

You can empty the contents of the plastic packaging into cereal bowls or other study containers to begin the sorting process. If you encounter shortages, please be sure the missing components aren't still stuck in the packaging material.

I supply replacement parts promptly and without question, Please, though- if you lost the parts in the carpet or the cat took them, you can tell me! That lets us know if it's something separate from a parts-list or quality-control issue.

We appreciate feedback on the instructions- we incorporate corrections and new material to make the experience more enjoyable for everyone!

---

All parts installed on the PC board should be fully seated unless otherwise noted.

---

### Static-sensitive Components:

- Keep these parts in the antistatic bag until you're ready to install them and handle them no more than necessary.
  - Ideally, you've got a grounded-tip iron, but if not- after the part is installed on the board and before soldering, touch the iron tip to shack ground (if available) or to a PC-board ground point.
- 

### Diode Installation:

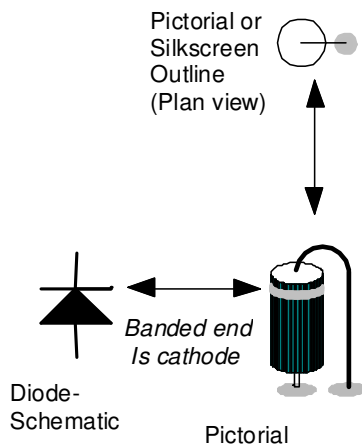

Some of the diodes are bent for "upright" or 'hairpin' installation on the board. Installation polarity is as shown below. Be sure to note the orientation of the circle on the pictorial illustration and install the diode to match this orientation. **The banded (cathode) end of the diode is always at the top.** For diodes which are installed 'lying down', match the banded end to that shown on the silkscreen and pictorial illustration.

- Resistor installation:

Many resistors are likewise installed in 'hairpin' fashion. As with the diodes, try to match the mounting orientation shown on the drawing. (If mounted as shown you've got better troubleshooting access to circuit points from the top side of the board.) Orientation of color bands on resistors and other non-polar devices is not critical.

- Installing IC sockets:

The "notch" or dot at one end should be oriented as shown in the pictorial drawings. Doublecheck orientation before soldering. *A suggestion-* solder down two opposite corners of each socket, and then go back and press a fingertip on the socket from underneath while reheating both connections in turn. You may then solder the remaining pads. This precaution ensures that the socket is well-seated on the PC board.

## ASSEMBLY INSTRUCTIONS:

***Do not install any capacitor in location C3-A until assembly is complete- see "Alignment"***

### Recommended Assembly sequence:

***There is no critical assembly sequence for this kit. In general, it's best to start at one corner of the board and work your way across. It's helpful to leave large components, e.g., the power semiconductors, T3 and the toroids until the last steps. This minimizes the weight of the board and parts you'll flip over repeatedly during assembly. It also minimizes the risk of component damage when you drop the board.***

Stuff only a few parts at a time (3-4 pieces). If you try to add too many parts at once between soldering operations, you may lose track and wind up with missing solder joints! Once you've stuffed the parts on the board, bend the protruding leads slightly outward to keep them in place while the board is inverted for soldering.

**Mount all components on the silkscreened side of the board. Solder components into place and trim leads after installation unless otherwise noted .**

Before you begin assembly, you may want to organize the parts supplied with this kit. If you've got room to spread out, it's helpful to organize components by value and set them aside. If you find shortages, contact us for prompt shipment of missing parts.

## ***READ and HEED!***

- Electrolytic capacitors and all semiconductors must be installed with the orientations shown in the pictorial diagram. If you inadvertently install an IC socket backwards, leave it! Simply install the IC itself with the 'notch' or pin 1 'dot' oriented as shown on the pictorial diagram.
- Crystals Y1-Y4 should be installed with a slight (1mm) gap between the crystal case and the board surface. A narrow strip of thin cardboard under the crystals serves as a good temporary spacer.
- Crystal Y3 requires a short jumper wire to ground from its case to a ground pad immediately to its left. Use a leftover piece of resistor-lead for this connection.
- It's important to make sure the wire leads on toroids have been stripped before installing the toroids on the board. You cannot count on the heat of a soldering iron to burn through the enamel wire coating.
- The 'flat' on diode D10 must be oriented as shown on the assembly pictorial
- **Transformer T3 is installed with the side with the letter 'P' facing toward L3 and the PA transistor.** The green side of the plastic winding bobbin faces the front edge of the board
- This kit includes a pair of heat sinks and 4-40 steel hardware- install these on the power semiconductors and tighten down.

- Toroidal inductor L2 should be restrained on the printed-circuit board using the nylon screw, nut and shoulder-washer supplied with the kit. This improves mechanical stability and reduces the chance of 'microphonics'.

## Wiring up the Retro-75:

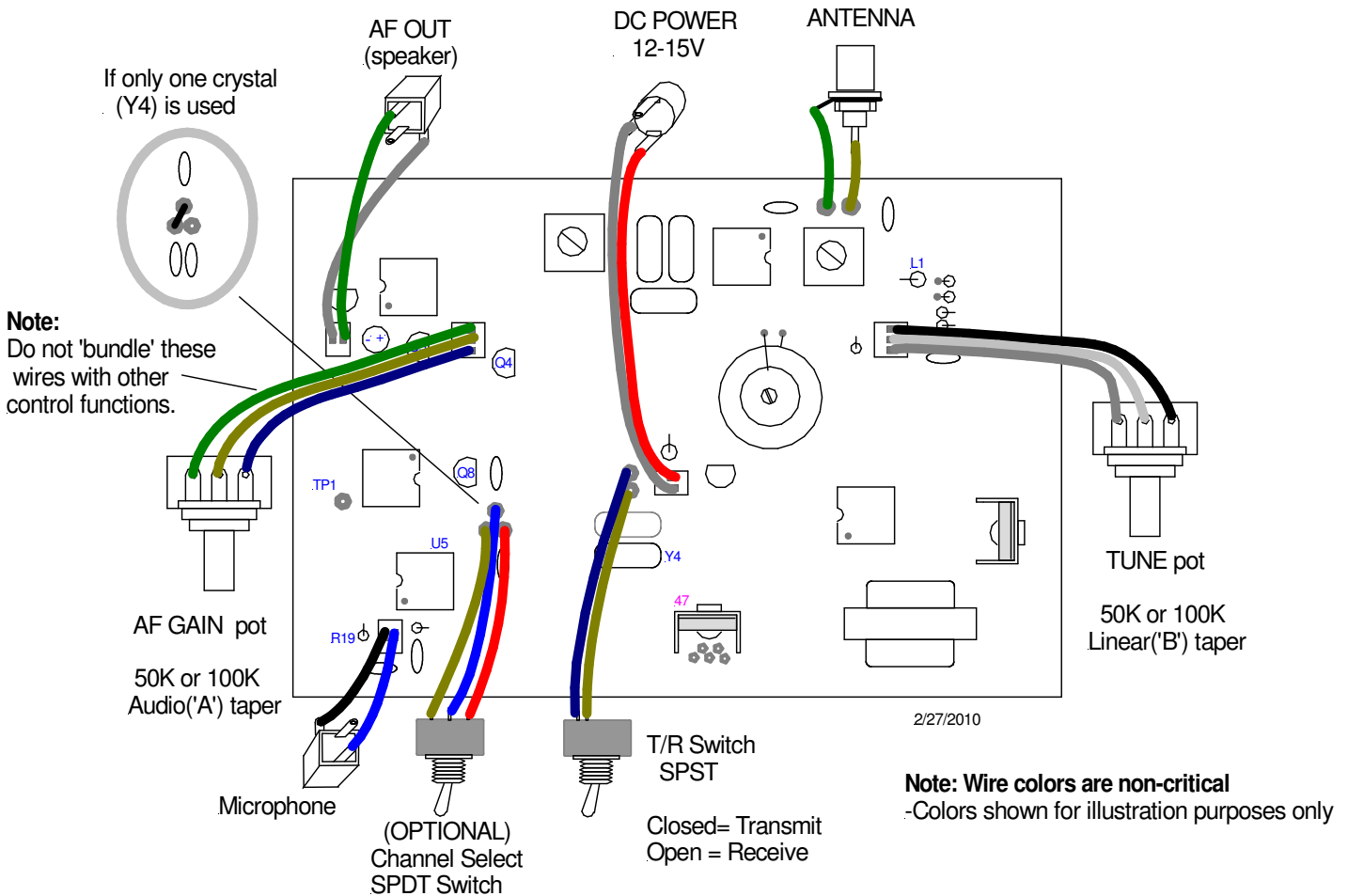

## Frequency selection:

The inset in the illustration above shows the crystal select function hard-wired to the 'Y4' position. Once a second crystal is installed, remove the hard-wire jumper. Wire the 'common' on an SPDT switch to the topmost pin of the trio and the two remaining switch leads to the two lower pads on the trio. Lead length to the SPDT switch is not critical.

## Checkout instructions:

If you have not done so already, install all ICs in their respective IC sockets with the orientations shown on the pictorial drawing.

Connect a 50-ohm dummy load to the antenna connector.

## Alignment Instructions:

There are 3 alignment steps for the Retro-75- these should be performed in the order given below.

- 1) Local Oscillator frequency
- 2) Receiver IF peaking
- 3) Receiver RF peaking

The tolerances on analog oscillator components (typically +/- 5%) mean that after assembling the oscillator, its operating frequency is uncertain. The oscillator must be calibrated for operation at the proper receiver frequency. *If you have a frequency counter, you may use it instead of the DC voltage table (below) to set the correct local oscillator (LO) frequency.*

The local oscillator frequency is  $(6.00 - F_{\text{operating}})$  MHz or about 2.1 Mhz. The frequency alignment procedure uses an on-board microcontroller (U4) which is coded as a frequency discriminator. Its output is a waveform whose DC average varies with frequency. [Higher LO frequency → higher voltage.]

### 1) LO Frequency Adjustment

Connect DC power to the PWR +/- points indicated on the pictorial drawing. *If you've installed D13 correctly, a reverse-polarity supply situation will not cause harm.*

Set the tuning pot to mid-scale (50% rotation).

Set the T/R switch to the closed (Transmit) position. Using a digital multimeter, measure the DC voltage at TP1 (left edge of board next to U4).

Temporarily install- **but do not solder**- a sample value of C3-A from the assortment supplied in the kit. Leave the capacitor leads long for the moment. This should change the indicated value of DC voltage from the step above. Use a fingertip to push the capacitor over slightly to ensure good contact with the board pads. Select the value of C3-A which yields a DC reading closest to 2.72 volts. *Note that because of the relationship between LO and IF, adding more capacitance lowers the LO frequency and hence raises the receiver operating frequency.*

Using a knife-point, adjust SMT capacitor C3 to fine-tune the DC reading. *The adjustment range of C3 is 18-20 kHz.*

This puts the center of the receiver's tuning range at **3885 kHz**.

Here's a more extensive set of values for tuning the receiver to other center-frequencies. Use the supplied 3885 kHz crystal at Y4 and set the 'TP1' DC voltage as follows:

Operating Frequency	LO Frequency	Application	DC Voltage at TP1
4000 kHz	2000 kHz		2.61 V
3900 kHz	2100 kHz		2.70 V
<b>3885 kHz</b>	2115 kHz	<b>U.S. East Coast</b>	2.72 V
<b>3870 kHz</b>	2130 kHz	<b>U.S. West Coast</b>	2.74 V
3800 kHz	2200 kHz		2.80 V
<b>3705 kHz</b>	2295 kHz	<b>Netherlands</b>	2.90 V
<b>3615 kHz</b>	2385 kHz	<b>United Kingdom</b>	3.00 V
3600 kHz	2400 kHz		3.02 V
3500 kHz	2500 kHz		3.14 V

Note: the current firmware version responds predictably to LO frequencies between the range of 1.8 to 2.8 MHz. Beyond those limits, it 'rolls over' and displays erroneous results. If the LO is not working or the signal into U4 is missing, adjustments to C3 or changing values of C3-A will not affect the DC voltage reading.

This is a one-time adjustment. When this step is completed, set the T/R switch to Receive mode (switch open). Remove DC power. Install the selected value of C3-A. Remove and save U4 (12C508A) for future use. *This ensures that U4 doesn't modulate the supply voltage with its varying current demand, inducing an audio 'whine' during normal operation.*

## 2) IF peaking

Set the AF gain pot for maximum gain. Touch a fingertip to R2 (1.5K), found just below Y3. Using a small slot screwdriver, adjust the slug in T2 for maximum shortwave broadcast reception. AM signals which do not respond to tuning slug travel are probably AM (medium-wave) broadcast signals and should be ignored. There'll be a distinct response peak for 6 Mhz signals. Remove fingertip.....(from R2).

## 3) Receiver RF peaking

Replace the dummy load with a 75M/80M antenna and using the tuning pot, tune for an amateur signal. Using a small slot screwdriver, adjust the slug in T1 for maximum received signal strength. Re-peak T2 as needed.

## Transmitter adjustments: None

AF gain is controlled by a built-in ALC function. For the recommended dynamic microphone (Radio Shack #33-3019)\*, 'close-talk' the microphone at approximately 1/4" from your mouth. If you're hitting the audio hard enough, LED D10 will just flicker faintly on voice envelope peaks.

Note: this is not what you'd call a 'good' microphone- it's simply inexpensive and widely available. If you need more audio 'highs' in your signal, decrease the value of R19 and scale the value of C25 upward by the same factor.

The Retro-75's carrier output power is 2 to 2.5 Watts. With audio modulation, the peak envelope power is 7-8 watts. The Retro-75 complies with current FCC requirements for waveform spectral purity.

- Additional transmit crystals are available from [www.af4k.com](http://www.af4k.com) – see 'HC-49/U crystals'.

---

\**"This just in"*- I've been advised that the recommended microphone is a 'Web-only' item, They carry the following dynamic mics in most of their stores:

Audio-Technica ATR-1100	RS # 55036964	\$9.99
Sony FV 100	RS# 55032942	\$9.99

If not, consider the following sources:

Audio-Technica ATR-30	(from online music stores)
Behringer XM-8500	(Amazon.com)

*Both of those are in the \$20 ballpark.*

## ***Further Thoughts on Microphones:***

Amateurs being what we are, the temptation to use other than the recommended microphones is probably irresistible. If you go this route, please be aware of the following:

### Dynamic Microphones:

Dynamic mics described as 'high-level' or 'preamplified' contain active internal circuitry. As such, they need a bias source to provide working voltages. Add a 2.2K ohm resistor from the mic input signal to a stable source of voltage. U5 pin 8 would be a good choice. [Connecting to the power supply voltage will yield distortion due to power supply pulling on voice peaks.

Further, the microphone signal levels will be too high with a preamplified mic. Replace R20 (100K) with a 10K resistor and C26 (330 pF) with a 3300 pF (.0033 uF) capacitor. This cuts the audio level to the modulator by a factor of 10 (20 dB) and reduces the resulting distortion.

### Ceramic Microphones:

The ceramic (piezoelectric) microphones provide high-level audio but require no working bias voltage. The classic D-104 microphone is the most familiar example of this type. Add a 100K-220K resistor in series with the microphone input. This reduces the Retro-75 audio gain to comfortable levels.

### Electret Microphones:

Not recommended. These microphones require a working bias, and their capacitive nature 'emphasizes' audio highs. If you must use one of these, a JFET buffer is a good idea, along with the series input resistance (above) to attenuate the high signal levels.

---

Check this out: there's now a user group at <http://groups.yahoo.com/group/SWLRetros75/>

---

Dave Benson, K1SWL  
[k1swl@earthlink.net](mailto:k1swl@earthlink.net)  
June 24<sup>th</sup>, 2011

(Mail:)

Small Wonder Labs  
P.O. Box 187  
Newport, NH  
03773 USA

## TROUBLESHOOTING:

[This page is under construction. Contact me for troubleshooting assistance in the meantime.]

I've had 3 reports of the PA and T3 overheating, sometimes to the extent that molten wax leaks out of T3. If you experience this problem, proceed as follows:

Briefly switch to Transmit and measure the DC voltage at pins 6/7 of U8 (the TC1412N). Chances are it measures about 6V DC. Remove power and remove U8. The 3.88 MHz oscillator is not working. [This may be doublechecked with a 'big rig' by looking for a steady carrier at the crystal frequency. If none found, examine all solder joints at Q11 and associated oscillator components- retouch as needed. Check also for presence of a jumper connection to enable either Y4 or Y5 to function.

Expected DC readings at Q11:

Emitter (@R33): 1-2V

Base (@R32): 0.6 V higher than Emitter reading

Collector: 6V