

Small Wonder Labs
PSK-40 Transceiver
Kit Assembly Instructions



Thanks for purchasing a Small Wonder Labs "PSK-40" transceiver kit!

Please take a few moments to look over the sections entitled "*First Things First*" and "*Building Instructions*" before you dive in. These sections contain information which is key to your success with this kit

TABLE OF CONTENTS:

First Things First.....	2
Materials	3
Parts List	4
Theory of Operation	6
Schematics	8
Pictorial Drawing.....	10
Building instructions , general.....	11
Grouped assy. Instr.....	12
"Hooking Up"	20
Alignment	21
Troubleshooting the "PSK-40 "	23
"Frequently Asked Questions"	24

THE FINE PRINT:

There are lots of small parts in this kit. With many of us getting older, this may prove troublesome. I highly recommend a magnifying glass or close-up glasses to check all solder joints and component codes.

THE OTHER FINE PRINT:

If you encounter conflicts between various sections of this document, contact me for a resolution. The following order of precedence applies:

- Schematic (most trustworthy)
- Parts list
- Pictorial
- grouped assembly text
- Everything else

TOOLS:

You'll need the following tools:

- Soldering iron- ~25W
- 60/40 solder, small diameter
- Diagonal cutters
- Needle-nose pliers
- Small slot screwdriver
- Wire-strippers (recommended)
- Tweezers (recommended)

TEST EQUIPMENT:

- Wattmeter (Radio Shack #21-534 / equiv.) (\$30)
- Multimeter (recommended)
- Amateur transceiver (recommended)

PSK-40 Power Requirements.

The PSK-40 is designed to operate with a minimum supply voltage of approximately 10V. A power supply capable of delivering a minimum of 1 Amp at 12-14 Volts DC is recommended. Maximum recommended supply voltage is 15VDC.

A low-cost supply suggestion: Jameco's #228822, 15V regulated 'wall-wart'. This supply requires a plug adapter, their #229155CL. They're at 800-831-4242.

Note: the less expensive unregulated 'wall-warts' will not provide adequately filtered DC- don't waste your

money! 'Filtered' is not sufficient- you need to see the word 'Regulated' on the description.

FIRST THINGS FIRST --Stuff worth knowing!

COLOR CODES:

Resistor color codes are given in the parts list. Radio Shack's Color-Code Guide, #271-1210, or the ARRL Handbook will help. If you're not sure, verify the resistor values with a multimeter before installing.

For what it's worth, roughly 8% of the male population is red/green color-blind. If you're one of these, you should be verifying all resistors with a multimeter before installing them.

The PSK-40 board is double-sided and all holes on the board are plated-through. This means that you do not need to solder on the top side of the board.

SOLDERING SKILLS

Hopefully this isn't your first experience with a soldering iron. If it is, though, or this is your first solid-state project, here are some tips to ensure your success:

- Soldering Iron:

Use a small iron in the 25-watt class (such as a Radio Shack #64-2070) and keep the tip clean. Use a moistened sponge or paper towel to clean the tip periodically as you work.

Apply only as much heat as is needed to get a good joint. A small vise to hold the printed-circuit board may make soldering easier.

Touch the soldering iron tip to the PC board trace and the component lead simultaneously. Within a second or two, apply solder and you'll see the solder flow onto the junction. Withdraw the solder and then the soldering iron.

Avoid the temptation to load solder onto the joint until no more will fit! This is an invitation for trouble, as solder bridges may form across the closer trace separations. Here's what the correct and incorrect joint treatments look like:

SOLDER FILLET IS CONCAVE AND 'WETS'
SMOOTHLY TO COMPONENT LEAD

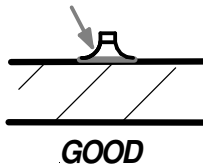

SOLDER FILLET IS CONVEX OR DOES NOT
ADHERE TO COMPONENT LEAD

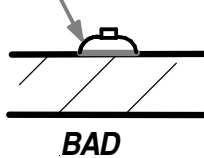

PLEASE READ THE SECTION BELOW BEFORE
REMOVING ANY PARTS FROM THE BOARD

Uh-oh! Sooner or later, you may need to remove a part installed in the wrong location, or perhaps pull a component for troubleshooting purposes.

Get yourself a roll of desoldering braid (Radio Shack #64-2090B). Lay the end of the braid down on the joint to be cleaned and press the soldering iron tip over the braid. Within several seconds you'll see the braid begin to wick up solder from the joint. Remove the braid and reapply a new section as needed until the joint is clean. It may be necessary to pull the component out from the top side of the board while heating the joint. Leave the iron tip on the board only as long as necessary to do the job- the PC-board traces will eventually delaminate (peel off) if overheated.

If that still doesn't do the job, it may be necessary to cut the offending part off on the top side and pull the remaining leads through with pliers. Contact me for replacement parts if necessary.

If you need to remove a transistor, I'd highly recommend sacrificing the part by snipping it off on the top side of the board. The leads are best pulled out singly to minimize the risk of lifting pads.

After removing a component from the board, the through-hole will probably still be blocked with solder. Use a dissecting needle or dental probe (explorer),

apply heat to the probe and the board trace simultaneously until the tool pushes through. Lacking either of these tools, a round wooden toothpick works well also!

WINDING TOROIDS:

-Count as you go. Draw each turn snug against the core to ensure a trim and tight winding

-Double-check the turns count when you're finished. Use your fingernail or small screwdriver to "bump" over each turn as you count- this is considerably easier than counting by eye.

- Trim the excess wire off to about 1/4" and strip the insulation off the ends with a wirestripping tool. (Make sure the stripper is adjusted correctly for the wire- it should cut the insulation cleanly but should not nick the wire itself- try this out on a sample length of toroid wire first.)

Counting the turns:

If the wire passes through the toroid center hole, it counts as a turn. Here's an example:

This toroid is wound with 8 turns

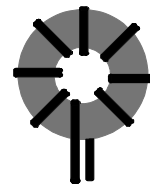

- Turns must be uniformly distributed around the circumference of the toroid.

MATERIALS-

You'll find the following items with your PSK-40 kit:

- 1- bag of parts, miscellaneous
- 1- antistatic bag (contains semiconductors)
- 1- poly bag- SMTs, 3 Zener diodes
- 1- poly bag (resistors/disk capacitors)
- 1- poly bag (monolithic capacitors)
- 1- printed circuit board
- (this manual)

(Feel free to reproduce portions of this manual for personal use. You can then check off the construction steps as you complete them, or make other notes and still keep the original clean.)

REFERENCE DESIGNATORS:

Each component is uniquely identified with a reference designator. Bypass capacitors are identified as C101 and up. Reference designators are shown in blue on the schematic pages.

COMPONENT IDENTIFICATION:

- Resistors and RF chokes

This manual describes the color coding for all resistors and RF chokes. Only the first three bands are described, the fourth band is a tolerance code, typically gold (=5%) and is not listed. All resistors are 1/4W 5% carbon film types, RF chokes are also an axial (leads out of each end) component but are notably larger.

- Capacitors:

Here's the general rule for capacitor nomenclature:

If 3 digits are printed on the capacitor, the first two are significant figures and the third is a multiplier.

Examples:

'471' = $47 \times 10^1 = 470$ pF

'103' = $10 \times 10^3 = 10,000$ pF = .01 uF

Letter suffixes: J=5%, K=10%, M=20%.

Please: If you're looking for a '104' monolithic cap, be sure to inspect both sides of the caps before concluding we gave you the wrong value!

Monolithic caps:

Monolithic caps are provided in their own poly bag. Capacitors are separated by value within this bag and are ordered by capacitance value. *The capacitors in this assortment are identified by shading on the parts list below.* Cut this bag open when you're ready to proceed, and store the groups of capacitors separately in marked envelopes or small paper cups.

If these parts are supplied with a 0.1" (2.5mm) lead-spacing for installation in a board hole-spacing of 0.2" (5 mm), bend the wire leads gently to spread the spacing. Avoid sharp bends right at the wire-lead exit from the epoxy case; this may cause component damage/failure.

- Extra information on components

There's often extraneous information marked on components. Examining a sample IC, I find "MC1458P1 KKJK 8949". You care only about the '1458' or other markings I've specified *If I've specified a capacitor '104' and you find the correct number of parts, but marked "104M", for instance, those are them!*

PARTS LIST

Quantity	Reference Designator	Value	Description	Markings or Ident.
1	C29	4.7 pF	Disk cap	4.7
10	C5-C9,C19-C23	22 pF	Disk cap	22
1	C38	4-20 pF	Trim cap	Red, 2 leads
1	C42	6-30 pF	Trim cap	<i>Pre-installed</i>
2	C1, C13	47 pF	Disk cap	47
2	C43,C44	56 pF	Monolithic cap	560
2	C39,C40	68 pF	Disk cap	68
1	C41	150 pF	Monolithic cap	151
7	C3,C32,C28,C30,C45-C47	220 pF	Monolithic cap	221
1	C37	330 pF	Monolithic cap	331
2	C34,C36	680 pF	Monolithic cap	681
4	C2,C27,C31,C35	1000 pF	Monolithic cap	102
1	C48	.001 uF	Poly cap	102, <i>red</i>
20	C4,10,11,C24-26,C101-105, C107-113,C118,C119	.01 uF	Disk cap	103
6	C12,16,33,C114,115,117	.1 uF	Monolithic cap	104
2	C15,C17	1 uF	Electrolytic cap	1 uF
1	C14	10 uF	Electrolytic cap	10 uF
1	C18	47 uF	Electrolytic cap	47 uF
2	C106,C116	220 uF	Electrolytic cap	220 uF

Parts list (cont'd)

Quantity	Reference Designator	Value	Description	Markings or Ident.
5	D1-D4,D8,D10	1N4148A	Diode	Glass body, on tape
-	D7,D10	-	<i>Reserved- not used</i>	
3	D5,D6,D9	1N5236B	Diode, 7.5V Zener	In marked bag-strip
1	D11	1N4001	Diode	1N4001
1	D12	1N5818	Diode	1N5818
1	HS1	- -	Heat sink, small	Black metal, w/ fins
1	HS2	- -	Heat sink, medium	Black metal, w/ fins
2	J1,J2	- -	3.5mm audio jack	3 leads, rectangular
1	J3	- -	Power jack, 2.1/5.5 mm	3 leads, rectangular
1	J4	- -	BNC, w/ lockwasher, nut	(Antenna jack)
1	L1	10 uH	RF choke	Brwn-blk-blk
3	L2,L5,L6	-	Slug-tuned inductor, 10 mm	'42IF123
1	L3	6.8 uH	SMT inductor	In marked bag-strip
1	L7	2.2 uH	SMT inductor	In marked bag-strip
1	L8	T50-6	Toroid, 14 turns #24	Yellow 'doughnut'
2	L9, L10	T50-6	Toroid, 19 turns #24	Yellow 'doughnut'
1	P1	- -	DC Power Plug, 2.1/5.5mm	<i>Plug, black body</i>
2	Q1,Q3	2N3906	Transistor, TO-92 pkg.	Small, plastic body
2	Q2,Q4	2N7000	Transistor, TO-92 pkg.	Small, plastic body
4	Q5,Q6,Q8,Q9	2N4401	Transistor, TO-92 pkg.	Small, plastic body
1	Q7	MPSH10	Transistor, TO-92 pkg.	Small, plastic body
1	Q10	2SC1970	Transistor, TO-220 pkg.	Large, metal tab
1	Q11	MRF261	Transistor, TO-220 pkg.	Large, metal tab
5	- -	- -	IC socket, 8-pin DIP	8 leads
2	R40, R41 [R42 omitted]	1.5 ohm	Resistor, 1/4w 5%	Brown-grn-gld-gld
4	R9,R33,R35,R38	6.8 ohm	"	Blue-grey-gld-gld
3	R25, R26,R39	51 ohm	"	Grn-brn-blk-gld
2	R2,R32	100 ohm	"	Brn-Blk-brown-gold
2	R30,R34	220 ohm	"	Red-red-brown-gld
6	R1,R3,R11,R22,R24,49	470 ohm	"	Ylw-viol-brown-gld
7	R6, R23,R29,R37,45,48,52	1K	"	Brown-blk-red-gld
1	R27	1.5K	"	Brown-grn-red-gld
3	R4,R12,R15	2.2K	"	Red-red-red-gld
5	R5,R7,R18,R21,R36	4.7K	"	Ylw-viol-red-gld
4	R10,R14,R16,R20	10K	"	Brn-blk-orange-gld
6	R13-A, R19,R31,R44,47,50	22K	"	Red-red-orange-gld
3	R13-B, R43,R46	47K	"	Ylw-viol-orange-gld
1	R8	510K	"	Grn-brn-yellow-gld
2	R17, R51	1M	"	Brn-blk-green-gld
1	T1	FT50-43	Toroid, 4 turns -see text	Grey 'doughnut'
2	T2, T3	-	AF Isolation transformer	<i>Mouser 42XL016</i>
3	U1,U2,U7	SA612AN	Integrated circuit	8 leads, plastic
2	U3,U4	LM1458	Integrated circuit	8 leads, plastic
1	U5	TUF-1	Mixer, metal can package	4 leads, in-line
1	U6	78L08	Integrated ckt, TO-92 pkg.	Small, plastic body
1	U8	MAR-3SM	Surface-mnt IC, <i>preinstalled</i>	Tiny- 4 leads

Parts list (cont'd)

Quantity	Reference Designator	Value	Description	Markings or Ident.
1	W1	- -	2' (0.7m) power wire	2-conductor
9	Y1-Y5,Y7-Y10	4.915 MHz	Crystal, series-load	
1	Y6	11.981 MHz	Crystal, series-load	
1	- -	- -	Printed-circuit board	'SWL 3/02'
1	- -	- -	Mica washer	
1	- -	- -	#4-40 x 1/4" nylon screw	
1	- -	- -	#4-40 x 1/4" steel screw	
2	- -	- -	#4-40 nut	
1	- -	- -	4' (1.3m) #24 magnet wire	
2		- -	4" (10cm) solid wire	Color varies

Theory of Operation:

This transceiver is a single PC-board design measuring 4.6" x 5.27" (12 x 13.4 cm). It is functionally a crystal-controlled SSB transceiver with slightly wider-than-normal IF passband characteristics. It covers the range of 7.070 to 7.073 Mhz.

Receiver Operation:

The receiver RF input (schematic point 'D') is applied through a series-tuned resonant circuit (C1/L1). Diodes D1-D4 limit during key-down and thereby restrict the signal levels presented to the receiver front-end during transmit. The double-diode configuration raises the network's intercept point with respect to W7EL's original configuration to improve IMD immunity. The combination of C2,C3 and L2 are a tuned circuit network which matches the input impedance (1.5K ohms) of mixer U1.

U1 is fed with a 11.98 Mhz Local Oscillator (LO) signal and converts the incoming 7.07 Mhz received signal to the 4.91 MHz Intermediate Frequency (IF). This mixer has approximately 12 dB of conversion gain. The transistor (Q1) following the mixer is configured as an amplifier with another ~12 dB of gain.

Y1-Y4 and associated capacitors are the IF filter. This filter has a 3-dB bandwidth of approximately 3.5 KHz and loss of roughly 2 dB. Its output is terminated by the combination of R5 (4.7K) and U2's input resistance

Product detector U2 receives the IF filter output and multiplies (mixes) it with a ~4.91 Mhz LO signal (from

schematic point 'E'. This results in an audio output at pin 5 of that IC. C13 provides rolloff of the audio to reduce high-frequency 'hiss'. Op-amp U3 and associated components provide audio amplification. This stage has a gain of approximately 100 (40 dB).

Because the active soundcard inputs are always active, even during transmit, the receiver must be 'muted' during transmit. Without this feature, the receiver output will be mixed back through the soundcard (in parallel with the desired DSP-based transmitter drive) and cause transmitted signal distortion. MOSFET Q2 provides this function by shorting the receiver output to ground during transmit.

T-R Switching:

T-R switching is controlled by dual op-amp U4 and associated components. The first section, U4-A, is configured as a peak detector with a gain of approximately 20 (26 dB). Incoming audio from the computer sound card causes the voltage at capacitor C16 to charge upwards in voltage. When the voltage is high enough, the op-amp section U4-B switches its output level from 'high' (~12V) to 'low' (~0-2V). This threshold corresponds to a power output slightly above 1W PEP [for a properly-adjusted PSK-40.]

The 'low' voltage at U4, pin 7 causes DC current to flow out of the base of Q3 (via R18) and turns on Q3. This circuit provide 'Vsw' used to bias a number of transmitter stages.

'Vsw' is at 0V during receive and switches to V+ (~12V) on transmit. This also turns on (unmutes) TX audio FET Q4. It also turns on RX muting FET Q2.

Transmitter operation:

Audio from the computer soundcard is applied to the transmitter via J2. Q4 is switched on during transmit and allows soundcard audio to reach the amplifier stage (Q5 and associated components). Note that when Q4 is off during 'receive', DC bias is removed from Q5 and it is also non-conducting. The combination of Q4 and Q5 provide relatively high attenuation (>60 dB) of the soundcard audio during receive. This is necessary since the transmitter's double-sideband (DSB) generator -U5- is running continuously- an audio signal applied to that stage's input would be plainly audible through the receiver. This situation would lead to soundcard feedback/distortion on receive without the presence of this muting function.

Single-sideband filtering is performed by a second filter comprising Y7-Y10 and related capacitors. After passing through the transmit IF filter comprising Y7-Y10 and related components, the signal has been reduced to a 4.91 MHz SSB signal. Its output drives 2nd mixer U7. This mixer is also driven by a signal from the 11.98 MHz LO, Colpitts oscillator Q9 and associated components.

The output of this mixer consists primarily of both the sum (16.89 MHz) and difference (7.07 Mhz) of the

frequencies applied to the mixer inputs. Q7 is an emitter follower used to buffer the high-impedance output of the mixer. U8 is a Monolithic Microwave IC (MMIC) and provides approximately 12 dB of gain.

Because the output of mixer U7 has energy on a number of frequencies, bandpass filtering is required to clean up its spectrum. L5, L6 and associated capacitors form this filter, with input and output impedances of 50 ohms.

Q10 and associated components are the transmitter's driver stage. This stage is feedback-controlled by R36 for good linearity and operates class-A (always conducting). The output of this stage is L-network matched via L7 and C33 to the Power Amplifier (PA) base. D11 biases the PA base to the threshold of conduction, necessary for linear operation.

The PA stage (Q11) features a bifilar transformer (T1) at its collector. This provides a 1:4 impedance match, transforming the PA collector impedance at rated power to 50 ohms. L8-L10 and C34-C37 are a 7-element low pass filter used to remove harmonic content from the PA output waveform. The design complies with current FCC requirements for spurious emissions. All harmonics were down at least 43 dB. The largest spurious output is down 50 dB.

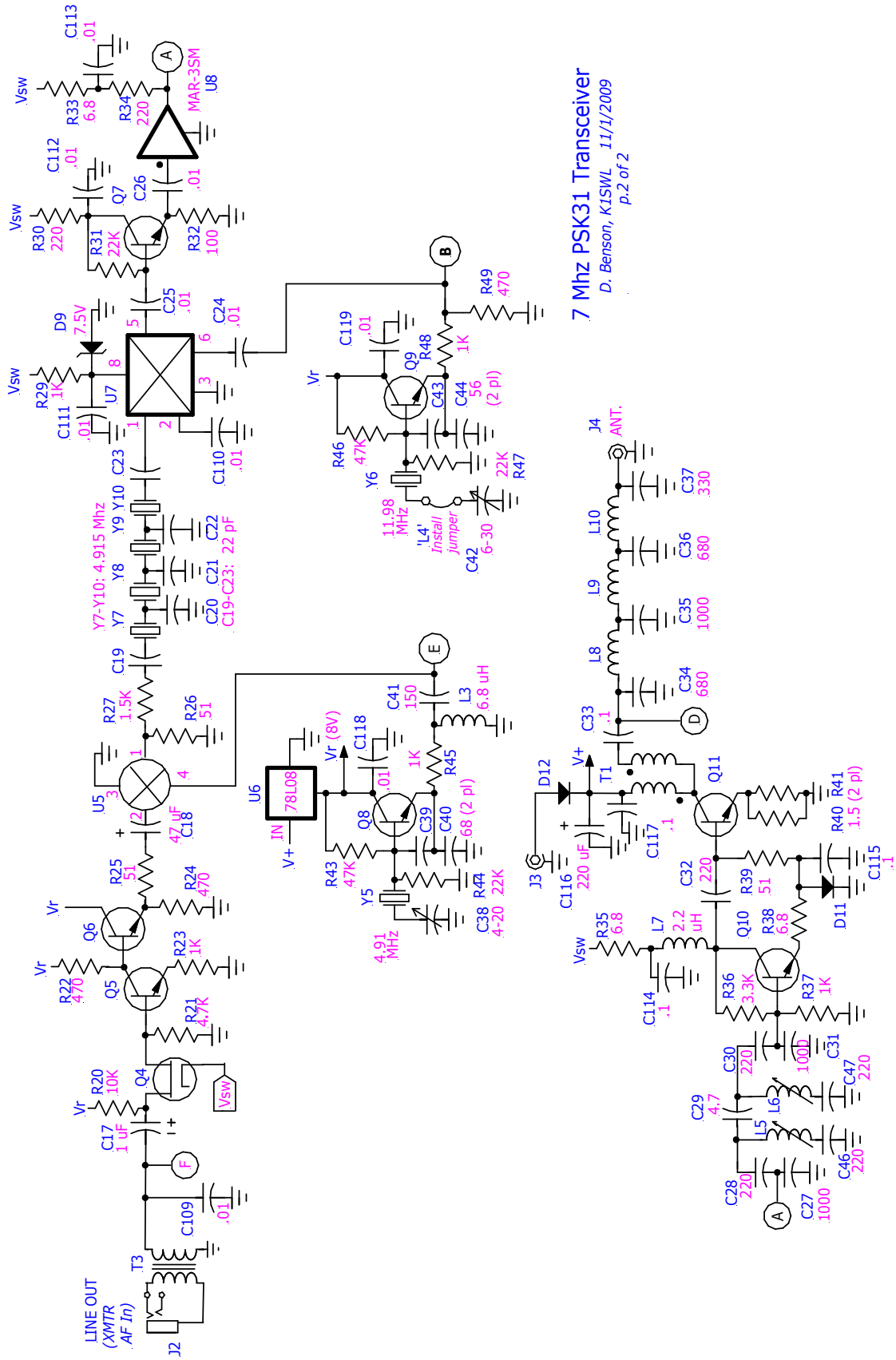

7 Mhz PSK31 Transceiver
 D. Benson, K1SWL 11/1/2009
 p.2 of 2

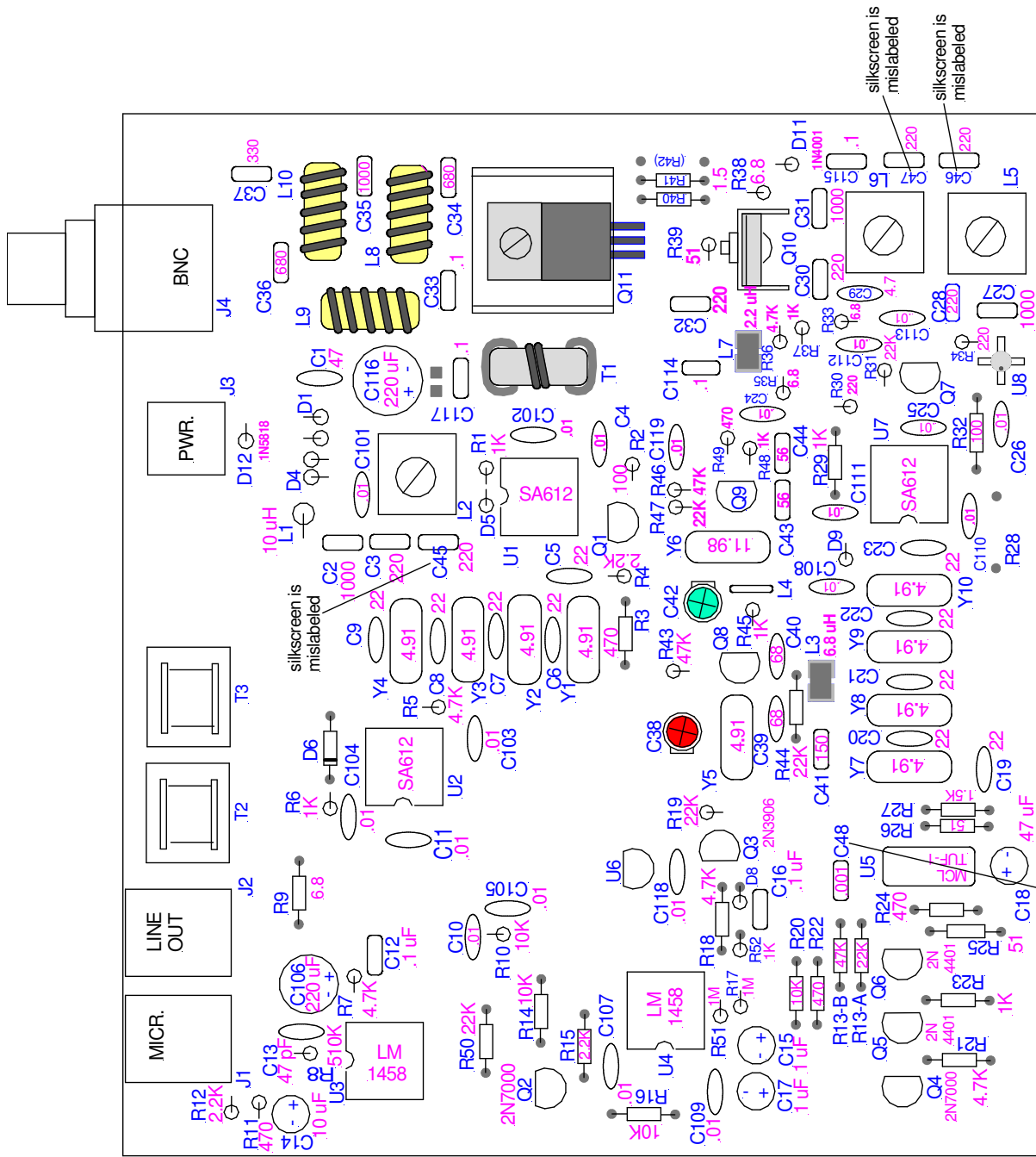

11/1/09

silkscreen is mislabeled

Building instructions:

All parts installed on the PC board should be fully seated unless otherwise noted in the assembly text..

Static-sensitive Components:

Components noted in bold in the assembly text are static-sensitive. The following general precautions apply:

- Keep these parts in the antistatic bag until you're ready to install them and handle them no more than necessary.
- Ideally, you've got a grounded-tip iron, but if not- After the part is installed on the board and before soldering, touch the iron tip to shack ground (if available) or to a PC-board ground point.
- Avoid placing these components on paper
- Diode Installation:

Some of the diodes are bent for "upright" or 'hairpin' installation on the board. Installation polarity is as shown below. Be sure to note the orientation of the circle on the pictorial illustration and install the diode to match this orientation. **The banded (cathode) end of the diode is at the top.** For diodes which are installed 'lying down', match the banded end to that shown on the silkscreen and pictorial illustration.

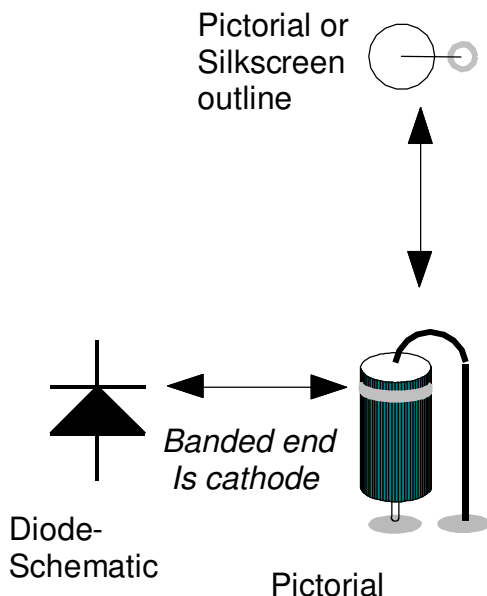

- Resistor installation:

Many resistors are likewise installed in 'hairpin' fashion. As with the diodes, try to match the mounting orientation shown on the drawing. (If mounted as shown you've got better troubleshooting access to circuit points from the top side of the board.) Orientation of color bands on resistors and other nonpolar devices is not critical.

- Installing IC sockets:

The "notch" or dot at one end should be oriented as shown in the pictorial drawings. Doublecheck orientation before soldering. A *suggestion*- solder down two opposite corners of each socket, and then go back and press a fingertip on the socket from underneath while reheating both connections in turn. You may then solder the remaining pads. This precaution ensures that the socket is well-seated on the PC board.

Recommended Assembly sequence:

I've specified the sequence detailed in the pages which follow, but there's nothing sacred about the order in which the board is populated. Some parts are best installed in a particular order, as noted within each group's instructions.

Directions for winding toroids are found within each group's assembly instructions.

Stuff only a few parts at a time (3-4 pieces). If you try to add too many parts at once between soldering operations, you may lose track and wind up with missing solder joints! Once you've stuffed the parts on the board, bend the protruding leads slightly outward to keep them in place while the board is inverted for soldering.

'The Real Men's Corner:'

This is for the folks who don't read instructions- you know who you are! Be aware of the following:

- Crystals and mixer U5 should be stood slightly (0.5 to 1mm) above the printed-circuit board to prevent shorts from case to ground.
- Do not omit the mica washer from under the PA transistor (Q11)- it's there for a reason!

- ASSEMBLY INSTRUCTIONS:

The following component is pre-mounted on the board: U8

Mount all components on the silkscreened side of the board. Solder components into place and trim leads after installation unless otherwise noted. You may find it convenient to install 3-4 parts at a time between soldering operations.

Group 1 Assembly:

Group 1 assembly installs the DC power circuitry.

- Install the DC power jack (black, 3 tabs) at J3. Note: there will be 'play' in the orientation of this part due to the slot widths - make sure it is carefully aligned square to the board edges before soldering all three tabs.
- Install diode D12 (1N5818) immediately below J3. Match the installation orientation as shown on the silkscreen.
- Install electrolytic capacitor C116 (220 uF). Observe the polarity marking on the device- the dark bar down one side of the part denotes the negative lead. Note that the longer of the two capacitor leads is (+).
- Assemble power cable using the 2' length of black twin-conductor wire. (unthread and remove the plastic shroud. The wire with the white-striped insulation is considered 'positive' and connects to the center conductor of the power plug. Once both leads are soldered, install the plastic shroud. Note: not to worry- the PSK-40 is reverse-polarity protected by D12.

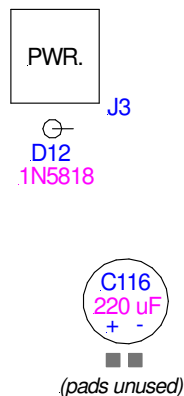

Group 2 Assembly:

(Group 2 assembly installs the Transmit/Receive switching circuitry).

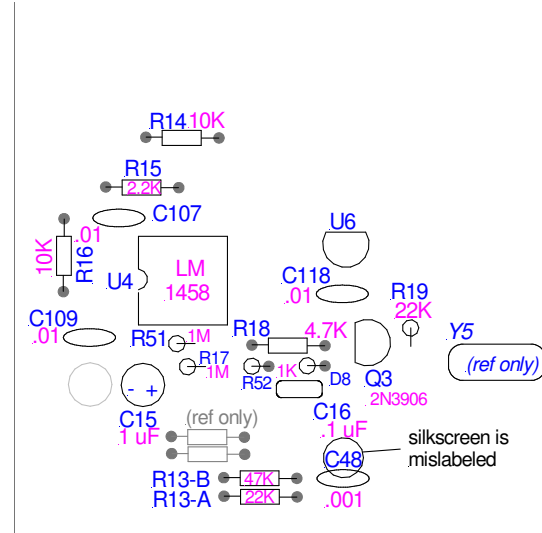

- Install an 8-pin IC socket at U4. Match the installation polarity as shown on the silkscreen and pictorial drawing. **Caution: before soldering, make sure that all 8 socket leads protrude through the board.**
- Install .01 uF ('103') disk capacitors at C107, C108, C109 and C118. **C108 not shown above- it's located to the right of SMT inductor L3.**
- Install resistors R14 and R16 (10K, brn/blk/org).
- Install resistor R15 (2.2K, red/red/red).
- Install 1N4148 diode D8. Match the installation polarity as shown on the silkscreen and pictorial drawing.
- Install resistors R17 and R51 (1M, brown- blk-green)
- Install resistors R19 and R13-A (22K, red-red-orange).
- Install resistor R13-B (47K, ylw-violet-org).
- Install resistor R18 (4.7K, ylw-violet-red)
- Install resistor R52 (1K, brown- blk-red)

- Install electrolytic capacitor C15 (1 uF). Match the installation polarity as shown on the silkscreen and pictorial drawing.
- Install poly cap C48 ('102'). **Note: the silkscreen is mislabeled as 'C38'.**
- Install monolithic capacitor C16 (.1 uF) ('104')
- Install a 2N3906 plastic transistor at Q3. Match the installation polarity as shown on the silkscreen and pictorial drawing..
- Install the 78L08 3-pin regulator at U6. Match the installation polarity as shown on the silkscreen and pictorial drawing..
- Install a 3.5 mm audio jack at 'J2' near the upper left corner of the board.
- Install an LM1458 IC in the U4 socket. You may wish to press the two rows of ICs gently together (I use a tabletop surface) to ease installation. Make sure that all pins seat firmly in the IC socket.
- Install trimmer capacitor C38 (**RED**). Be sure to orient the 'flat' side of the capacitor body as shown on the pictorial and silkscreen.
- Install one of the 4.91 Mhz crystals at Y5. Install this component slightly above the board (0.5 to 1 mm) to prevent the case from shorting to board traces. *This is best accomplished by installing and soldering the crystal in place and then retouching the connection while pulling gently on the component to lift it slightly.*
- Install capacitor C41 (150 pF monolithic).
- Install capacitors C39 and C40 (68 pF disk).
- Install resistors R45,R48 (1K- brn-blk-red). **Note: R48 is not on board silkscreen.**
- Install resistors R43,R46 (47K-ylw-viol-org).
- Install resistors R44,R47 (22K-red-red-org).
- Install transistors Q8 and Q9 (2N4401, from antistatic bag). Match the orientation of the flat side of the components to that of the silkscreen.
- Install the single 11.98 Mhz crystal at Y6. Provide height clearance as noted previously for Y5 for this and all remaining crystal installations.
- Using a length of leftover wire lead from a resistor, install a short wire jumper at the two holes identified on the printed-circuit board as 'L4'.
- Install R49 (470 ohm, yellow/violet/brown).
- Install C43 and C44 (56 pF monolithic caps).
- Install C24 and C119 (.01 uF disk caps).

Group 3 Assembly:

Group 3 assembly installs the 4.9 Mhz and 11.98 Mhz local oscillators.

- Install surface-mount inductor L3 (6.8 uH, from bag strip). *Note: the inductor itself is inside a black plastic carrier.* **Pre-tin the inductor pads on the PC board sparingly with solder before installing the part.** Place this component on the two pad locations and restrain carefully in place with tweezers. Tack one end down with the soldering iron, solder the other end sparingly, and retouch the end originally tacked down. **Good component alignment is important to ensure that there are no short-circuits- check your work carefully for solder bridges.**

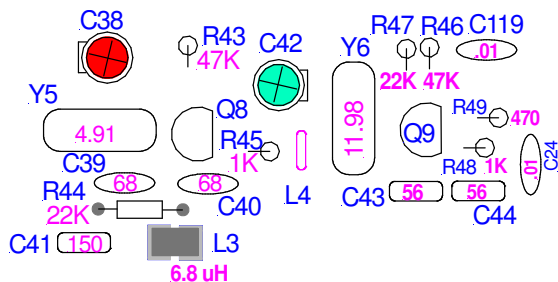

Group 4 Assembly:

Group 4 assembly installs the receiver AF amp, product detector and crystal filter

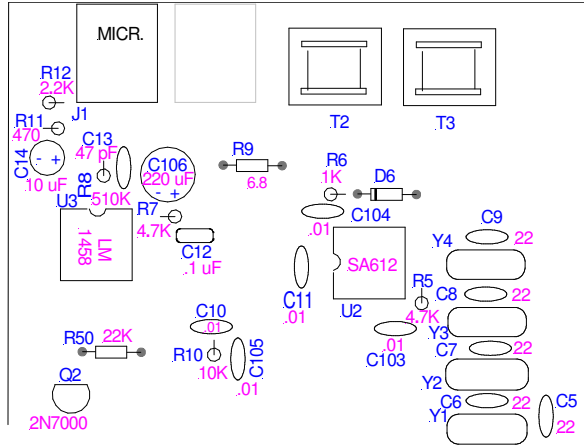

- Install 8-pin IC sockets at U2 and U3. Match the installation polarity as shown on the silkscreen and pictorial drawing. **Caution: before soldering, make sure that all 8 socket leads protrude through the board.**
- Install resistor R12 (2.2K, red/red/red).
- Install resistor R5 (4.7K, yellow/violet/red)
- Install resistor R11 (470 ohm, ylw-viol-brown).
- Install resistor R8 (510K, grn-brn-yellow).
- Install disk capacitor C13 (47 pF).
- Install audio jack J1 at the upper left corner of the board.
- Install electrolytic capacitor C14 (10 uF). Match the installation polarity as shown on the silkscreen and pictorial drawing.
- Install resistor R7 (4.7K, ylw/viol/red).
- Install resistor R9 (6.8 ohm, blue/grey/gld).
- Install .01 uF ('103') disk capacitors at C10, C11, C103, C104 and C105.

- Install electrolytic capacitor C106 (220 uF). Match the installation polarity as shown on the silkscreen and pictorial drawing.
- Install a .1 uF monolithic capacitor ('104') at C12.
- Install resistor R10 (10K, brn/blk/org).
- Install a 7.5V Zener diode (from bag strip) at D6. Match the installation polarity as shown on the silkscreen and pictorial drawing.
- Install resistor R6 (1K, brn/blk/red).
- Install resistor R50 (22K, red/red/orange).
- Install disk capacitors C5-C9 (22 pF).
- Install 4.91 MHz crystals Y1-Y4.
- Install jumper wires from the unlabeled single holes to the left of Y1 and to the right sides of Y2 and Y4. [Place the board on the workbench surface and stand a resistor upright in these holes. Solder on the top side of the board and cut the lead to a length of ~1/8" (4mm).] Save the resistors for later use.
- Bend the free end of each wire over to the nearest crystal and solder each wire to the crystal can. [The crystal cans are tinned and will accept solder readily. *Use no more heat than necessary to ensure a good connection.*]
- Install a 2N7000 transistor at Q2. **This part is static-sensitive.** Match the installation polarity as shown on the silkscreen and pictorial drawing.
- Install transformers T2 and T3. **Note:** primary and secondary windings are identical. Installation orientation is non-critical
- Install a LM1458 IC from the antistatic envelope) at U3. Match the installation polarity as shown on the silkscreen and pictorial drawing.
- Install an SA612 IC from the antistatic envelope) at U2. Match the installation polarity as shown on the silkscreen and pictorial drawing.

Group 5 Assembly:

Group 5 assembly installs the receiver 'front end'. The receiver portion of the PSK-40 will be functional upon completion of this group.

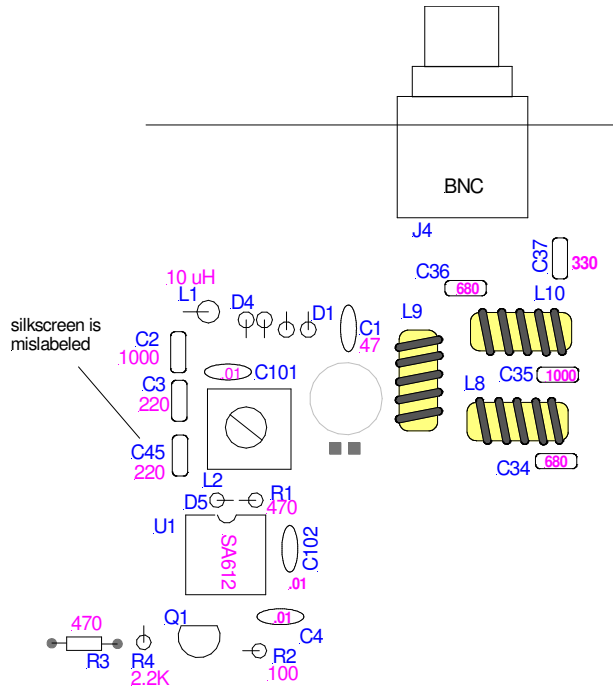

- Install 1N4148 diodes at D1, D2, D3 and D4. Match the installation polarity as shown on the silkscreen and pictorial drawing.
- Install C1 (47 pF disk capacitor)
- Install a 10 RF choke (brown/blk/blk) at L1.

Note: the monolithic capacitors below are somewhat fragile. **If supplied with a 0.1" lead spacing, but installed on pads with a 0.2" lead spacing, proceed as follows:** Grasp the capacitor body between thumb and forefinger. Spread the wire leads apart outward, taking care not to bend the leads right at the capacitor body. The wire leads may then be re-bent a few mm away from the capacitor body to re-form them at the correct parallel spacing.

- Install 1000 pF ('102') monolithic caps at C2 and C35.
- Install 220 pF (221') monolithic caps at C3 and C45. **Note: the silkscreen for C45 is incorrectly maked as 'C39'.**

- Install 680 pF ('681') monolithic caps at C34 and C36.
- Install a 330 pF ('331') monolithic cap at C37.
- Install a slug tuned inductor (metal can) at L2.
- Install a .01 uF ('103') disk capacitors at C4, C101 and C102..
- Install a 7.5V Zener diode (from bag strip) at D5. Match the installation polarity as shown on the silkscreen and pictorial drawing.
- Install resistor R1 (470 ohm, ylw/violet/brn).
- Install an 8-pin IC socket at U1. Match the installation polarity as shown on the silkscreen and pictorial drawing. **Caution: before soldering, make sure that all 8 socket leads protrude through the board.**
- Install resistor R2 (100 ohms, brn/black/brown).
- Install resistor R3 (470 ohm, ylw/viol/brn).
- Install resistor R4 (2.2K ohm, red/red/red).
- Install a 2N3906 transistor at Q1. Match the installation polarity as shown on the silkscreen and pictorial drawing.
- Install an SA612/SA602 IC at U1. Match the installation polarity as shown on the silkscreen and pictorial drawing.

L8, L9, L10 Winding Instructions:

- Using an 12" (30 cm) length of magnet wire, wind **14** turns on one of the 0.50" (1.2 cm) diameter **yellow** toroids. After passing the wire through the center hole each time, pull it snug against the toroid as you proceed. Ensure that each turn lays flat on the core-'crossed' or scramble-wound turns must be avoided.
- Doublecheck the turns count, adjust the spacing between turns for a uniform appearance. **Review the toroid sketch on page 3 carefully. Mis-counting the turns is a common source of difficulty for newer builders.**

- Trim the excess wire ends to a length of ~3/8" (1 cm). Each lead-end must be gently scraped with a sharp knife or hobby knife blade to remove the enamel insulation. **Do not omit this step, and do not count on your soldering iron to melt the enamel.**
- Install this prepared toroid at 'L8'.
- Using an 15" (40 cm) length of magnet wire, wind **19** turns of wire on a T50-6 (**yellow**) toroidal core. Prepare the toroid for installation in the manner described above.
- Install this prepared toroid at 'L9'.
- Using an 15" (40 cm) length of magnet wire, wind **19** turns of wire on the remaining T50-6 (**yellow**) toroidal core. Prepare the toroid for installation in the manner described earlier..
- Install this prepared toroid at 'L10'.
- Install the BNC connector at J4. Solder all pins.

* *

Group 6 Assembly:

Group 6 assembly installs the audio switch and transmit first mixer.

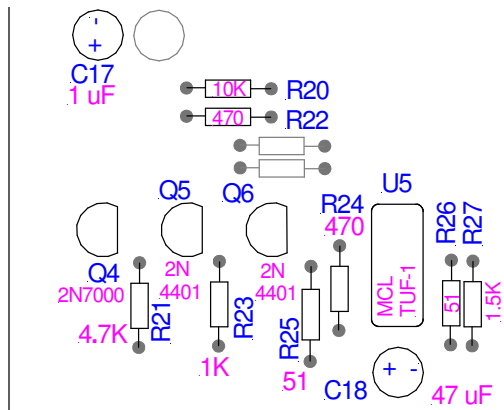

- Install a 1 uF electrolytic capacitor at C17. Match the installation polarity as shown on the silkscreen and pictorial drawing.
- Install resistor R20 (10K, brn/black/org).

- Install resistors R22 and R24 (470 ohm, ylw/violet/brn).
- Install resistor R23(1K ohm, brn/blk/red)
- Install resistor R21 (4.7K, yellow/violet/red).
- Install resistor R25 ((51 ohm, grn/brown/black).
- Install resistor R27 (1.5K ohm, brown/grn/red).
- Install resistor R26 (51 ohm, grn/brn/black).
- Install Q4 (2N7000- from antistatic bag). Match the orientation of the flat side of the component to that of the silkscreen. **This part is static-sensitive.**
- Install Q5 and Q6 (2N4401- from antistatic bag). Match the orientation of the flat side of the components to that of the silkscreen
- Install Mixer U5 (MCL TUF-1), from antistatic bag). **Be sure that the part labeling is oriented as shown on the figure on this page and that the part correctly overlaps the silkscreened outline on the board.**

Caution: This component should be spaced slightly above the board. Solder only 1 of the 4 pins into place initially. Adjust component spacing above the board while briefly re-heating this connection, then solder the remaining connections.

- Install a 47 uF electrolytic capacitor at C18. Match the installation polarity as shown on the silkscreen and pictorial drawing.

* *

Group 7 Assembly:

Group 7 assembly installs the transmitter IF filter and second mixer stages.

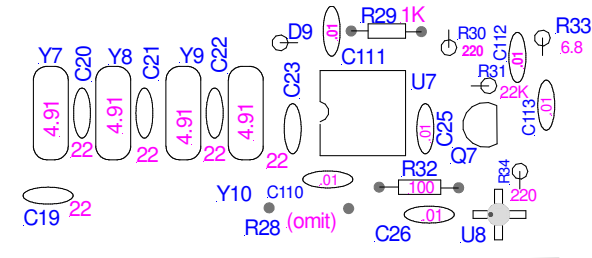

- Install C19 through C23 (22 pF disk caps).
- Install the remaining four 4.91 MHz crystals at Y7-Y10.
- Install crystal ground leads to the left of Y7 and below Y8, Y9 and Y10 following the procedure detailed earlier (group 4).
- Install an 8-pin IC socket at U7. Match the installation polarity as shown on the silkscreen and pictorial drawing. **Caution:**

before soldering, make sure that all 8 socket leads protrude through the board.

- Install R29 (1K, brown/blk/red).
- Install D9 (7.5V Zener- from bag strip). Observe the installation polarity as shown on the silkscreen.
- Install .01 uF ('103') disk capacitors at C25, C26, C110, C111, C112 and C113
- Install R30 and R34 (220 ohms, red/red/brown).
- Install R31 (22K, red/red/orange).
- Install R32 (100 ohm, brown/blk/brown).
- Install R33 (6.8 ohm, blue/grey/gold).
- Install Q7 (MPSH10, from antistatic bag). Match the orientation of the flat side of the component to that of the silkscreen.

* *

Group 8 Assembly:

Group 8 assembly installs the transmitter bandpass filter and driver stages.

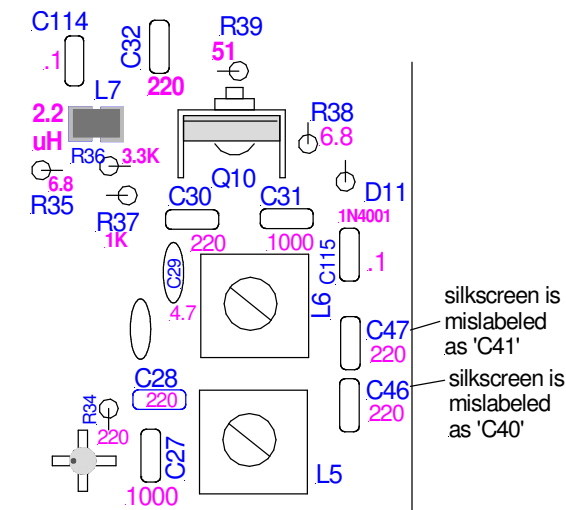

- Install L7 (2.2 uH SMT inductor, from the bag strip).
- Install C27 and C31 (1000 pF monolithic caps, '102').
- Install C28 and C30 (220 pF monolithic caps, '221').
- Install C29 (4.7 pF disk capacitor).
- Install capacitors C32, C46, and C47 (220 pF monolithic cap, '221'). **Note: the silkscreens for C46 and C47 are incorrect.**
- Install L5 and L6 (remaining two metal-can tunable inductors)
- Install R37 (1K, brown/blk/red).
- Install R36 (4.7K, yellow/viol/red).
- Install R35 and R38 (6.8Ω, blue/gry/gold).
- Install R39 (51Ω, green/brn/black).

- Install C114 and C115 (.1 uF monolithic cap, '104') **Note: C115 not labeled on silkscreen.**
- Install D11 (1N4001, power diode). Observe the installation polarity as shown on the silkscreen and pictorial.
- Install Q10 (2SC1970, from antistatic bag). Observe the component's tab orientation as shown on the silkscreen. **The metal tab is to the rear; the lettering faces the front of the board.**
- Install the smaller heatsink on the 2SC1970 using a **metal** screw and nut. Use the heat-sink orientation (i.e., 'hole-up') which results in the lower height above the board when installed.
Tighten the hardware.
- **Caution: Ensure that R39 's wire lead is not touching the heat sink.**

Group 9 Assembly:

Group 9 assembly installs the transmitter final amplifier.

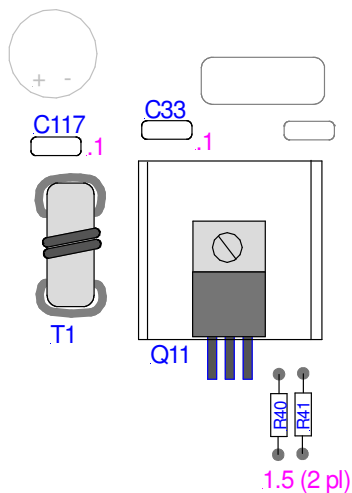

- Install C33 and C117 (.1 uF monolithic capacitors, '104').

T1 Winding Instructions:

- Using the two 4" (10cm) lengths of solid wire, wrap this wire-pair snugly around the toroid for one complete turn. It should look like this:

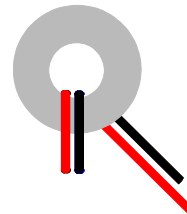

- Proceed to thread the wire pair through the hole again and draw it snug. Repeat this threading operation twice more (a total of 4 wire-pair turns through the hole in all).

Caution:

The wires must not cross over each other as they are laid down on the core (i.e., there are no 'twists' built into the wire. If (color 1) is on the leading edge in the direction you're winding, it must continue on the leading edge for all 4 turns.

'Clockwise' and 'counterclockwise' winding senses are non-critical- either one is fine.

Here's what the result looks like:

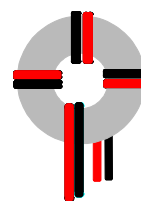

Note the way the color-pairs are arranged as they proceed around the core.

- As you look through the toroid hole (as shown above, confirm that the 2 (first color) leads protruding are on the left and the 2 (other color) are on the right.
- Cut the protruding leads to a length of 1/2", strip these with the wirestripping tool and install at **T1**. Doublecheck the insulation colors before soldering this component down.

(Assuming your wires are red and black, the red leads go to the two 'upper' T1 mounting-holes and the black leads go to the 'lower' T1 mounting-holes. Or the reverse- it doesn't matter. *Your wire colors may vary.*

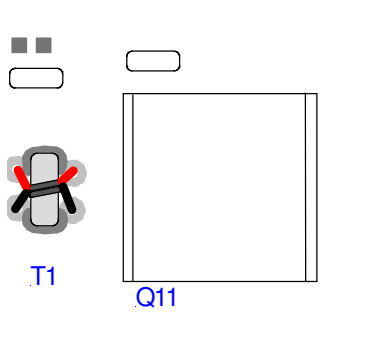

aligned parallel with the board before tightening the nut. ***Tighten cautiously- the nylon screw threads will strip at the torque typically used for steel hardware.*** Solder Q11's leads into place.

Caution: do not substitute a metallic screw here!

That's it- board assembly is complete!

CLEAN UP YOUR ACT! Before you proceed to checkout, grab some cotton swabs and use acetone (nail polish remover) or isopropyl alcohol to remove solder flux from the underside of the PC board. The result is a much cleaner appearance once you've completed this step. ***Use acetone cautiously on the top side of the boards- some of the plastic components may be softened by contact with it.***

- Install R40 and R41 (1.5 ohms, brown/green/gold). *Note: R42 is omitted*
- Using a small screwdriver blade (or 8-10d common nail) as a 'form', bend the 3 leads of the MRF261 transistor downward at a 90° angle as shown, immediately outboard of the wide portion of the leads. **Take care to ensure the resulting bent leads are uniformly distant from the transistor body.**

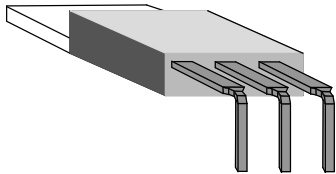

- Cradle the transistor within the large heat sink so that the hole in the transistor tab lines up with that of the heatsink's hole.
- 'Sandwich' the mica washer between the transistor and the heat sink so that all three layers' holes line up.
- Insert the **nylon** 4-40 machine screw downward through the aligned holes in this 'sandwich'.
- Use a fingertip to secure the nylon screw in place, place this assembly on the board, insert Q11's three leads into the corresponding holes in the board. *(Do not solder yet.)* Secure in place with a steel nut on the underside of the board. . Make sure that the heat sink is

Hooking Up:

The figure below shows the interconnect between the PSK-40 board and the outside world (more on alignment later)

Before the "Smoke Test":

○ Inspect your work to ensure there are no solder bridges or unsoldered joints. Check to see that the ICs are mounted in their proper orientations, or install them if you haven't already done so (*see p.10 for placement*).

PSK-40 Mechanical Details

The board itself may be mounted in an enclosure at the board's four corners, using #4 machine screw hardware. #4 spacers should be used to separate the PC board from the enclosure by 3/16" or more. (#4 hex nuts are an acceptable substitute for spacers.)

Enclosures may be found in a variety of styles. Radio Shack offers several types of metallic enclosures. I'd especially recommend Hosfelt Electronics, Inc., who carry enclosures offered by a number of companies. There's no minimum order, and they can be reached at [800] 524-6464 for a

catalog. Ten-Tec also offers a complete line of enclosures, and they support small orders as well! Call [800] 231-8842 for a free brochure.

The enclosure option for this transceiver is a black/ grey extrusion enclosure with a companion custom-punched end panel. The board size is tailored to fit the enclosure side-rail slots and the custom panel fastens to the BNC connector for mechanical integrity. Information on this enclosure may be found at:

<http://smallwonderlabs.com>

under 'PSK31'.

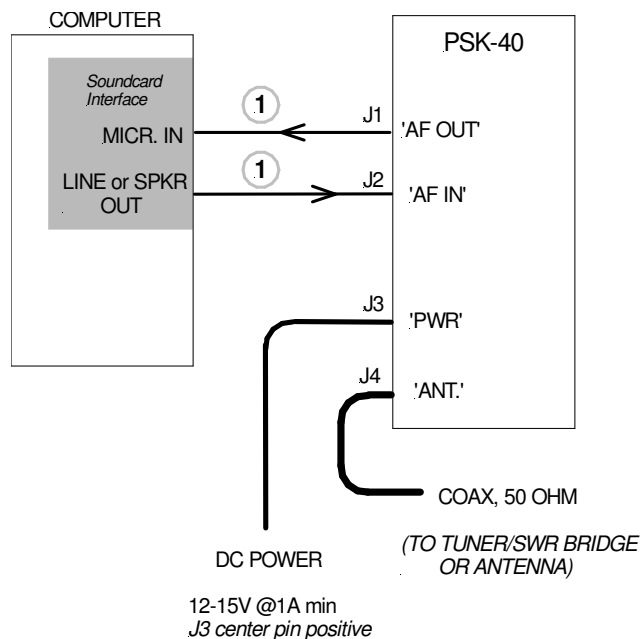

CABLE DESCRIPTION:

- ① 3.5mm stereo (3-cond) to 3.5mm stereo (3-cond)
- Radio Shack # 42-2387A
- (2 required)

Alignment Instructions

- If you have not already done so, install all 8-pin ICs in their respective sockets. *It may be helpful to bend each row of IC leads inward by pressing it gently on a table surface- this will ease installation.* Doublecheck the IC locations and orientation before proceeding.

Receiver Alignment:

- Connect a 3.5mm (1/8") 3-conductor shielded cable between your computer soundcard Microphone input and the PSK-40's AF OUT jack (J1).
- If you have not already done so, download the DigiPan application software. Here is link to the software:

<http://digipan.com> Version 2.0 is current as of 2009

Here is a link to a site with additional PSK31 information which you may find useful:

<http://psk31.com>,

The "Software" link on that page will also take you to the DigiPan software site.

- Open the DigiPan application and click on the Configure menu option, select "Waterfall Drive". Make sure "Microphone" is checked and advance the microphone gain to maximum (see Frequently Asked Questions', p.24, for details).
- **Note: If you're running Windows Vista, the waterfall drive and transmitter drive pull-downs are inoperative. Use the Speaker icon at the lower right corner of your screen for transmitter drive adjustments. The microphone./line In controls may be accessed via your computer's 'Control Panel' under 'Sound'.**
- Open the DigiPan application and click on the Configure menu option, select "Waterfall Drive". Make sure "Microphone" is checked and advance the microphone gain to maximum (see Frequently Asked Questions', p.24, for details).
- On DigiPan's Configure menu option and select 'Band'. Select '40M' and set the start

frequency is set to '7070' and the sideband selection is 'USB'.

- Connect a 50-ohm antenna to J4.
- Using the supplied tuning tool (white plastic), set inductor L2 to approximately halfway along the slug travel.
- Install the power plug at J3 and connect DC power (12-15V).

The area on your computer screen below DigiPan's frequency scale has been black. It should now contain yellow 'sparkles' once power is applied.

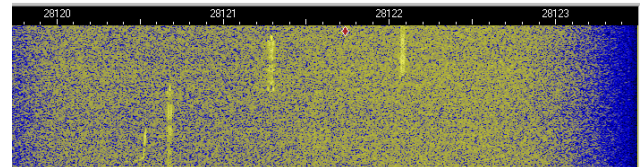

/ This image was taken with the 'microphone' gain at maximum, an antenna connected, and C38 adjusted to center the 'yellow band' onscreen. (The yellow band is considerably more apparent with a strong noise source.)

The left edge of the screen corresponds to 7070 KHz.

- Adjust trimmer capacitor C38 (above Y5) with a small slot screwdriver to center the noise picture in the panoramic display window. *When centered, the dark edges of the display should appear roughly symmetrical in width (See note below). If you have a high-resolution monitor, the display may be more than 4 KHz wide; if so, perform the centering using the leftmost 4 KHz of the display only.*
- Adjust inductor L2 for brightest yellow noise background **Note:** *If you encounter difficulty seeing the background noise on the DigiPan display, it may be helpful to turn on a motor-driven appliance as a noise source. [A hair-dryer, for instance, does a nice job!]*
- Connect a 3.5mm (1/8") 3-conductor shielded cable between your computer soundcard LINEoutput and the PSK-40's AF IN jack (J2).

Frequency Alignment:

- Using the computer mouse, click the DigiPan display point immediately below the '7072' frequency tick mark. The 'diamond' symbol will jump to that location.
- Using a 'big rig', transmit a CW signal on 7072.0 (into a dummy load, please). A bright signal line should appear somewhere within the frequency display. If not, rotate trimmer C42 1/8th turn (45°) using a knife-point.. Repeat as needed until the signal line appears. Adjust C42 (left of Y6) until the bright line's position is lined up with the '7072' tick mark.

If you do not have a signal source, perform the first part of this alignment step until you find PSK31 signals and center them in the display.

Receiver Alignment is now complete.

- To copy PSK31 signals, click the mouse cursor on the center of the signals and copy should appear shortly thereafter in the upper text window.

Transmitter Alignment:

Caution: You must perform the receiver alignment before aligning the transmitter!

- Remove the antenna from J4 and connect a dummy load in its place. (If no dummy load is available, proceed using the antenna.)
- Click on the DigiPan 'Configure' menu option and select 'Transmitter drive'. Set the soundcard 'Wave' or 'All Waves', etc., slider level to maximum. Set the slider level on the master volume slider to one-half scale and close that dialog box.
- Click on 'TX' on the DigiPan menu bar. Using a multimeter set on 'DC Volts', (return lead to board ground) verify that the voltage on the case of Q10 (TX driver) jumps up to ~12V. This confirms that the transmitter bias is being switched on. *If the PA is getting hot due to prolonged key-downs, you may return to receive by clicking on 'RX' on the DigiPan menu bar.*

- Adjust the Master Volume control slider to correspond to an output power of approximately one watt. *(This step ensures that the transmitter is not being overdriven- it makes the results of the next adjustment step easier to interpret.)*
- Adjust inductors L5 and L6 for maximum wattmeter indication.
- Readjust both inductors for maximum wattmeter indication. *(This step is necessary because there's some interaction between the settings on the two inductors.)*

Transmitter Operational Adjustment:

Select the DigiPan 'Mode' 'Tune' menu option and adjust the master volume slider (lower right corner of screen- speaker icon) upward until output power no longer increases. Note the power reading and click 'OK' to stop transmitting.

- If your wattmeter has a choice of 'PEP' or 'AVG(CW)', set it to 'AVG(CW) '.

Click on 'T/R' on the menu bar. This places the transmitter in an idle pattern and has a 50% duty cycle. Adjust the master volume slider until the power output is at one-half the power value noted in the step above.

[Ideally the power ratio between 'Tune' and 'Idle', ('transmit' with nothing being typed) is 2:1. If there's not much difference in those relative power indications you're likely overdriving the transmitter.

In actual operation, as you type on the computer keyboard, you should see the output power flicker upward by about 25%. There is a brief burst of full-power carrier from DigiPan at the end of each transmission, this meter indication will be the same as for the 'tune' power level.

If you have an oscilloscope:

Click on TX and set the output envelope just below the level where distortion becomes noticeable. This will be on the order of 40V p-p, depending on power supply voltage.

Troubleshooting the PSK-40:

The "bugs" you're most likely to encounter often turn out to be caused by the simplest of problems. If your "PSK-40" doesn't play, here are some general troubleshooting guidelines.

"It works better plugged in!"

We've all heard that expression before, but unfortunately it's true. Ensure that DC power is getting to the PSK-40. A board with no voltage anywhere probably isn't getting power.

General guidelines:

Check once more for solder bridges and missing solder joints. Probing a suspect section of the circuitry with a fingertip or insulated tool will sometimes bring a stubborn circuit to life- if so, check again for a bad connection!

Of the returns I see, about 85% of the problems are caused by cold solder joints, 5% by solder bridges and 5% due to incorrect resistor installation. That leaves only 5% for all the other problems put together. Enough said!

- Ensure that the ICs are installed in the correct location and with the right orientation.
- Likewise ensure that the transistors and all diodes are installed with the correct orientation.

Receiver troubleshooting- general:

Starting at the AF amp (U4-B) input, probe with a small screwdriver or similar metal tool- there should be some indication of a signal on the computer's panoramic display. Repeat this probing, moving back 'upstream' (toward the receiver input) through the signal path. If there's a stage where the chain is broken and there's no longer any response, chances are good that's where a problem is!

Transmitter troubleshooting- general:

If an RF signal is getting to the transmitter final stage, but there's no apparent output, check the following:

- measure DC continuity with an ohmmeter across R40-R42 to ground. This reading should be approximately 0.5Ω .

Doublecheck the installation of T2- a miswire here assures there'll be virtually no RF output!

If you don't turn up anything with the above steps, see the troubleshooting information. It's located under the PSK-40 URL listed on page 2 of this manual

- The figure below illustrates IC pinout. The "pin 1 at lower left" convention applies to all Dual-Inline-Package (DIP) ICs.

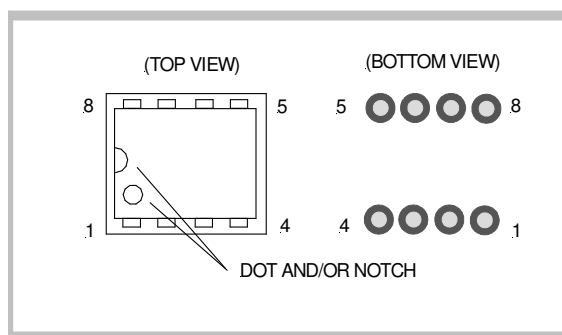

"Strange but True"- In general, the ICs themselves shouldn't be prime suspects during the troubleshooting process. Despite their complexity, they're very reliable, and I've had to replace these parts at the rate of only 1 for every thousand or so shipped!

- If you're still stumped, contact me for further technical support:

Dave Benson, K1SWL
P. O. Box 187
Newport, NH 03773
e-mail: K1SWL@earthlink.net

Troubleshooting is available for a flat \$45 fee. The unit will be returned to you in working condition and will include a troubleshooting report. **Contact me for shipping instructions before sending the unit in.**

FREQUENTLY-ASKED QUESTIONS:

- **How do I adjust the soundcard settings?**

With DigiPan already opened, click on Configure and select 'Spectrum drive'- the following appears

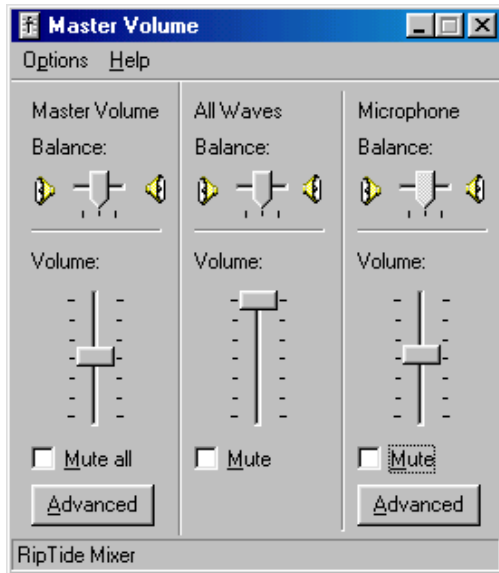

The master volume setting affects drive to the transmitter and may also be accessed by clicking on the speaker icon in on the Windows task bar (lower edge of screen, right end.) Double-clicking this icon brings up the dialog box above.

You may use the slider under "Microphone" to set receiver levels.

You may single-click on the speaker icon to get just the master volume slider. This control adjusts the transmitter drive levels. *Try starting with Half-scale.*

- **I've clicked on a good signal but nothing's showing up!**

There are several possible causes.

- Make sure it's a PSK31 signal- it should have the typical 'railroad tracks ' appearance on the display. If it's just a pair of vertical lines, it's an 'idling' pattern and there's no information being sent.
- If the signal is badly smeared by propagation conditions, the phase information may be lost - PSK31 is susceptible to polar (auroral) flutter. These tracks will appear blurry and indistinct.

- DigiPan has an adjustable squelch threshold. Click on the 'SET' menu choice at the top of DigiPan and select "Squelch Threshold"- check to ensure the threshold slider isn't set too high for the signal you've selected and adjust if needed.

- **What is the 'IMD' indication and how it used?**

Whenever DigiPan detects an idling pattern on a received signal, it calculates an intermod figure by measuring sideband energy at the frequencies which are generated by a overdriven transmitter. Note: your QRP signal may be near the noise floor to begin with- an IMD reading obtained from operators you're in QSO with may not be meaningful under these conditions

- **Why do some signals have extra lines on either side of them?**

If the pairs of extra lines are spaced 31 Hz apart, the station is overdriving the transmitter. The IMD reading will be poor. The good news is that other operators will be quick to point this out!

If the lines are spaced 60 (or more usually) 120 Hz apart, the station's power supply regulation is inadequate and AC ripple is superimposed on the desired modulation. If you use an unregulated supply, you'll be getting reports of this behavior!

- **When a strong signal comes on, the screen gets a lot 'busier'.**

The soundcard may be getting overdriven. The lower half of the trace below shows extra (spurious) signals. Reducing the microphone gain slightly eliminates the extra signals (top half of trace).

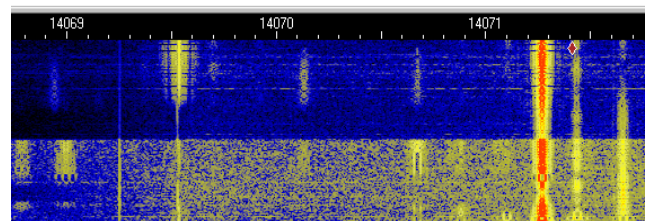

And a final note-:

- *Remove DC power from the PSK-40 when it's not in use. You're probably using your soundcard for other applications when you're not on the air. If the rig is left powered, you might broadcast your favorite music CD to the world, and that's a no-no!*