

Small Wonder Labs
PSK-40 Transceiver
Board Kit Instructions

Thanks for purchasing one of the Small Wonder Labs "PSK-40" transceiver kits!

Please take a few moments to look over the sections entitled "*First Things First*" and "*Building Instructions*" before you dive in. These sections contain information which is key to your success with this kit

Note: This version of the printed-circuit board features all through-hole capacitors and only one SMT part (U8). Please refer to the enclosed sketch for placement of .01 disk capacitors and IC sockets for U3 and U7 and install those components during assembly. The parts list has been revised to reflect this change.

TABLE OF CONTENTS:

First Things First.....	2
Materials	3
Parts List	4
Theory of Operation	6
Schematics	8
Pictorial Drawing.....	10
Building instructions , general.....	11
Grouped assy. Instr.....	12
"Hooking Up"	22
Alignment	23
Troubleshooting the "PSK-40 "	25
Appendix 1: "Frequently Asked Questions".....	26

THE FINE PRINT:

There are lots of small parts in this kit. With many of us getting older, this may prove troublesome. I highly recommend a magnifying glass or close-up glasses to check all solder joints and component codes.

THE OTHER FINE PRINT:

If you encounter conflicts between various sections of this document, contact me for a resolution. The following order of precedence applies:

- Schematic (most trustworthy)
- Parts list
- Pictorial
- grouped assembly text
- Everything else

Documentation updates may be found at:

http://smallwonderlabs.com/psk_docs.htm

TOOLS:

You'll need the following tools:

- Soldering iron- ~25W
- 60/40 solder, small dia.
- Diagonal cutters
- Needle-nose pliers
- Small slot screwdriver
- Wire-strippers (recommended)
- Tweezers (recommended)

TEST EQUIPMENT:

- Multimeter

PSK-40 Power Requirements.

The PSK-40 is designed to operate with a minimum supply voltage of approximately 10V. A power supply capable of delivering a minimum of 1 Amp at 12-14 Volts DC is recommended. Maximum recommended supply voltage is 15VDC.

FIRST THINGS FIRST --*Stuff worth knowing!*

COLOR CODES:

Resistor color codes are given in the parts list. Radio Shack's Color-Code Guide, #271-1210, or the ARRL Handbook will help. If you're not sure, verify the resistor values with a multimeter before installing.

For what it's worth, roughly 8% of the male population is red/green color blind. If you're one of these, you should be verifying all resistors with a multimeter before installing them.

The PSK-40 board is double-sided and all holes on the board are plated-through. This means that you do not need to solder on the top side of the board.

SOLDERING SKILLS

Hopefully this isn't your first experience with a soldering iron. If it is, though, or this is your first solid-state project, here are some tips to ensure your success:

- Soldering Iron:

Use a small iron in the 25-watt class (such as a Radio Shack #64-2070) and keep the tip clean. Use a moistened sponge or paper towel to clean the tip periodically as you work.

Apply only as much heat as is needed to get a good joint. A small vise to hold the printed-circuit board may make soldering easier.

Touch the soldering iron tip to the PC board trace and the component lead simultaneously. Within a second or two, apply solder and you'll see the solder flow onto the junction. Withdraw the solder and then the soldering iron.

Avoid the temptation to load solder onto the joint until no more will fit! This is an invitation for trouble, as solder bridges may form across the closer trace separations. Here's what the correct and incorrect joint treatments look like:

SOLDER FILLET IS CONCAVE AND 'WETS'
SMOOTHLY TO COMPONENT LEAD

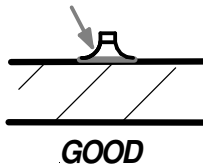

SOLDER FILLET IS CONVEX OR DOES NOT
ADHERE TO COMPONENT LEAD

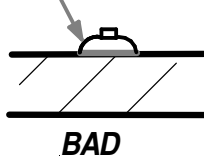

PLEASE READ THE SECTION BELOW BEFORE
REMOVING ANY PARTS FROM THE BOARD

Uh-oh! Sooner or later, you may need to remove a part installed in the wrong location, or perhaps pull a component for troubleshooting purposes.

Get yourself a roll of desoldering braid (Radio Shack #64-2090B). Lay the end of the braid down on the joint to be cleaned and press the soldering iron tip over the braid. Within several seconds you'll see the braid begin to wick up solder from the joint. Remove the braid and reapply a new section as needed until the joint is clean. It may be necessary to pull the component out from the top side of the board while heating the joint. Leave the iron tip on the board only as long as necessary to do the job- the PC-board traces will eventually delaminate (peel off) if overheated.

If that still doesn't do the job, it may be necessary to cut the offending part off on the top side and pull the remaining leads through with pliers. Contact me for replacement parts if necessary.

If you need to remove a transistor, I'd highly recommend sacrificing the part by snipping it off on the top side of the board. The leads are best pulled out singly to minimize the risk of lifting pads.

After removing a component from the board, the through-hole will probably still be blocked with solder. Use a dissecting needle or dental probe (explorer),

apply heat to the probe and the board trace simultaneously until the tool pushes through. Lacking either of these tools, a round wooden toothpick works well also!

WINDING TOROIDS:

-Count as you go. Draw each turn snug against the core to ensure a trim and tight winding

-Double-check the turns count when you're finished. Use your fingernail or small screwdriver to "bump" over each turn as you count- this is considerably easier than counting by eye.

- Trim the excess wire off to about 1/4" and strip the insulation off the ends with a wirestripping tool. (Make sure the stripper is adjusted correctly for the wire- it should cut the insulation cleanly but should not nick the wire itself- try this out on a sample length of toroid wire first.)

Counting the turns:

If the wire passes through the toroid center hole, it counts as a turn. Here's an example:

This toroid is wound with 8 turns

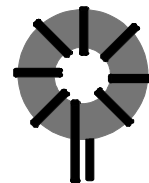

- Turns must be uniformly distributed around the circumference of the toroid.

MATERIALS-

You'll find the following items with your PSK-40 kit:

- 1- bag of small parts (resistors, caps, wire, etc)
- 1- antistatic bag (contains semiconductors)
- 1- envelope labeled "Zeners"
- 3- envelopes labeled 'L5', 'L6' and 'L10'
- 1- printed circuit board
- (this manual)

(Feel free to reproduce portions of this manual for personal use. You can then check off the construction steps as you complete them, or make other notes and still keep the original clean.)

REFERENCE DESIGNATORS:

Each component is uniquely identified with a reference designator. Bypass capacitors are identified

as C101 and up. Reference designators are shown in blue on the schematic pages.

COMPONENT IDENTIFICATION:

- Resistors and RF chokes

This manual describes the color coding for all resistors and RF chokes. Only the first three bands are described, the fourth band is a tolerance code, typically gold (=5%) and is not listed. All resistors are 1/4W 5% carbon film types, RF chokes are also an axial (leads out of each end) component but are notably larger.

- Capacitors:

Here's the general rule for capacitor nomenclature:

If 3 digits are printed on the capacitor, the first two are significant figures and the third is a multiplier.

Examples:

'471' = $47 \times 10^1 = 470$ pF

'103' = $10 \times 10^3 = 10,000$ pF = .01 uF

Letter suffixes: J=5%, K=10%, M=20%.

Please: If you're looking for a '104' monolithic cap, be sure to inspect both sides of the caps before concluding we gave you the wrong value!

Monolithic caps:

The printing on these parts is tiny! I'd highly recommend using a magnifying glass to verify component values before installing them.

If these parts are supplied with a 0.1" (2.5mm) lead-spacing for installation in a board hole-spacing of 0.2" (5 mm), bend the wire leads gently to spread the spacing. Avoid sharp bends right at the wire-lead exit from the epoxy case; this may cause component damage/failure.

- Extra information on components

There's often extraneous information marked on components. Examining a sample IC, I find "MC1458P1 KKJK 8949". You care only about the '1458' or other markings I've specified *If I've specified a capacitor '104' and you find the correct number of parts, but marked "104M", for instance, those are them! 'Dr. Suess' called it 'Calculatus Eliminator' - a wise man indeed!*

IF Transformer (T1):

Although not illustrated on the schematic for reasons of drawing clarity, T1 contains an internal capacitor within its base. Do not remove this capacitor.

PARTS LIST

Quantity	Reference Designator	Value	Description	Markings or Ident.
1	C35	10 pF	NPO disk cap	'10' or '10J'
1	C44	4-20 pF	6mm trimmer cap	Red
1	C48	6-30 pF	6mm trimmer cap	Green
10	C8-C12,C25-C29	22 pF	5% NPO disk cap	'22' or '22J'
2	C1, C17	47 pF	5% NPO disk cap	'47' or '47J'
2	C49,C50	56 pF	5% C0G cap, monolithic	'56J' or '560J'
3	C7,C45,C46	68 pF	5% NPO disk cap	'68' or '68J'
1	C51	68 pF	5% C0G cap, monolithic	'68' or '68J'
1	C47	150 pF	5% C0G cap, monolithic	'151' or '151J'
1	C13	220 pF	5% disk cap	'221' or '221J'
1	C38	220 pF	5% C0G cap, monolithic	'221' or '221J'
3	C3,C34,C36	270 pF	5% C0G cap, monolithic	'271' or '271J'
2	C40,C43	330 pF	5% C0G cap, monolithic	'331' or '331J'
2	C41,C42	680 pF	5% C0G cap, monolithic	'681' or '681J'
3	C4,C33,C37	1000 pF	5% C0G cap, monolithic	'102' or '102J'
27	C2,5,6, 14,16,C30-32, C101-106,C108-C117, C122-124	.01 uF	disk capacitor	"103" or "103M"
6	C15,19,39,C118,C119,C121	.1 uF	monolithic cap	'104'
2	C21,C22	1 uF	electrolytic cap	
1	C20	3.3 uF	electrolytic cap	

Parts list (cont'd)

Quantity	Reference Designator	Value	Description	Markings or Ident.
2	C18,C23	10 uF	electrolytic cap	
1	C24	47 uF	electrolytic cap	
2	C107,C120	220 uF	electrolytic cap	
13	D1-D7,D10,D13-D17	1N4148	signal diode	(On tape strip)
2	D8,D9	1N5236	7.5V zener diode	In 'Zeners' envelope
2	D11,D12	1N4001	1 Amp rectifier diode	(heavy leads)
3	J1-J3		3.5mm stereo jack	
1	J4		DB-9 (serial port) connector	
1	J5		2.1/5.5 mm power jack	
1	J6		BNC jack	
1	L1	10 uH	5% RF choke	Brn-blk-blk-gold
1	L2	2.2 uH	5% RF choke	Red-red-gold-gold
3	L3,L8,L9	2.2 uH	Tunable coil, metal-can	"TKANS 9447"
1	L6	6.8 uH	self-shielded SMT inductor	In 'L6' envelope
1	L4	22 uH	5% RF choke	Red-red-blk-gold
1	L5	18 uH	self-shielded SMT inductor	In 'L5' envelope
1	L7	2.7 uH	5% RF choke	Red-violet-gold-gold
1	L10	2.2 uH	self-shielded SMT inductor	In 'L10' envelope
2	L11,L13	T50-6	toroidal inductor, 18 turns	Yellow core
1	L12	T50-6	toroidal inductor, 19 turns	Yellow core
1	Q1	J310	JFET	plastic pkg.
1	Q2	2N2222A	NPN transistor	metal pkg.
1	Q3	2N3906	PNP transistor	plastic pkg.
2	Q4,Q12	2N7000	MOSFET transistor	plastic pkg.
4	Q5-Q8	2N4401	NPN transistor	plastic pkg.
1	Q9	MPSH10	NPN transistor	plastic pkg.
1	Q10	2N2219A	NPN transistor	metal pkg
1	Q11	2SC2078	NPN RF power transistor	TO-220 pkg., 'C2078'
3	R54-R56	1.5 ohm	Resistor, 1/4W, 5%	Brn-grn-gold-gold
5	R7,R17,R47,R51,R52	10 ohm	"	Brn-blk-blk-gold
4	R1,R39,R41,R53	51 ohm	"	Green-brwn-blk-gold
5	R2,R8,R13,R38,R46	100 ohm	"	Brn-blk-brwn-gold
2	R4,R10	150 ohm	"	Brn-grn-brn-gold
4	R20,R35,R44,R48	220 ohm	"	Red-red-brn-gold
2	R6,R34	470 ohm	"	Yellow-viol-brn-gold
2	R9,R11	680 ohm	"	Blue-grey-brn-gold
6	R5,R14,R43,R49,R60,R63	1K ohm	"	Brn-blk-red-gold
1	R42	1.5K	"	Brn-grn-red-gold
5	R3,R12,R24,R37, R57	2.2K	"	Red-red-red-gold
4	R19,R30,R32,R50	4.7K	"	Yellow-viol-red-gold
7	R15,R18,R23,R25,R27,R29, R33,	10K	"	Brn-blk-org-gold
6	R26,R28,R36,R45,R58,R61	22K	"	Red-red-org-gold
1	R22	33K	"	Org-org-org-gold
3	R31,R59,R62	47K	"	Yellow-viol-org-gold
1	R16	510K	"	Grn-brn-yel-gold
1	R21	1M	"	Brn-blk-grn-gold
1	T1	10.7 MHz	IF Transformer, metal can	"42IF123"
1	T2	FT50-43	4 turns bif. winding,see text	grey toroid
2	U1, U6	TUF-1, TFM-2	Mixer	4-pin metal can

Parts list (cont'd)

Quantity	Reference Designator	Value	Description	Markings or Ident.
1	U2	MC1350	IF Amplifier IC	8-pin DIP IC
2	U3,U7	SA612/602AN	Mixer IC	8-pin DIP IC
1	U4	LM1458	Dual op-amp IC	8-pin DIP IC, '1458, '4558','5558' or 'HA17458'
1	U5	LM393	Dual comparator IC	8-pin DIP IC, 'XX393'
1	U8	MAR-3SM	Microwave IC,	Pre-mounted on board
1	U9	78L08	Voltage regulator IC	TO-92 pkg.
9	Y1-Y5,Y7-Y10	4.915 MHz	Crystal	HC-49/U pkg.
1	Y6	11.98 MHz	Crystal	HC-49/U pkg.
5			8-pin DIP IC socket	
1			4-40 x 1/4" machine screw	
1			4-40 Nylon nut	
1	HS1		TO-220 heat sink	
1	W1		2' (0.7m) power wire	
1	P1		2.1/ 5.5mm coaxial plug	
1	W2		Telephone wire, 5' (12 cm)	
1	W3		#24 magnet wire, 4' (120 cm)	
1			Tuning wand, plastic	white

Theory of Operation:

This transceiver is a single PC-board design measuring 4.6" x 5.27" (7 x 10 cm). It is functionally a crystal-controlled SSB transceiver with slightly wider-than-normal IF passband characteristics. It covers the range of 7.070-7.074 MHz.

Note: Further description of this design is found in the June 2000 issue of *QST* magazine, as originally published for the 20M version.

Receiver Operation:

The receiver RF input (schematic point 'D') is applied through a series-tuned resonant circuit (C1/L1) and limiter (D1-D4) to a low-gain preamplifier stage comprising Q1 and associated components. The output of this preamp is slug-tuned via inductor L3.

Diode-ring Mixer U1 is fed with a 11.98 MHz Local Oscillator (LO) signal and converts the incoming 7 MHz received signal to the 4.91 MHz Intermediate Frequency (IF). Q2 and associated circuitry are a mixer post-amp and provide both gain and a termination for the mixer. The post-amp is followed by a 6-dB resistive attenuator with two-fold purpose: it

provides a stable load to the post-amp and reduces filter passband ripple.

Y1-Y4 and associated capacitors are the IF filter. This filter has a 3-dB bandwidth of approximately 3.5 KHz and loss under 2 dB. Its output is terminated by R12 (2.2K and U2's input resistance. IF amplifier U2 provides about 30 dB of gain and also serves as the control point for the AGC function (more on this later). The IF amplifier output is coupled to the product detector via T1, a tuned IF transformer.

Product detector U3 receives the 4.91 MHz IF amplifier output and multiplies (mixes) it with a 4.91 MHz LO signal (from schematic point 'E'). This results in an audio output at pin 5 of that IC. C14 provides rolloff of the audio to reduce high-frequency 'hiss'. Op-amp U4-B and associated components provide audio amplification. This stage has a gain of approximately 50 (34 dB) and provides additional lowpass audio filtering as well. The output of this stage is considerably larger than your computer's soundcard expects to see, and the combination of R19 and R20 attenuates this signal down down a 'soundcard-friendly' level.

Because the active soundcard inputs are always active, even during transmit, the receiver must be 'muted' during transmit. Without this feature, the receiver output will be mixed back through the soundcard (in parallel with the desired DSP-based transmitter drive) and cause transmitted signal distortion. MOSFET Q12 provides this function by shorting the receiver output to ground during transmit.

T-R Switching:

T-R switching is controlled by dual comparator U5 and associated components. 'RTS' or 'DTR' (DigiPan uses RTS). is provided by the host computer via the serial port connection, and is a bipolar signal of approximately +/- 10V in amplitude. It is negative (-10V) on receive and switches positive on Transmit. U5-A rests at 0V during receive and switches to V+ on transmit. This turns on (unmutes) TX audio FET Q4. It also turns on RX muting FET Q12.

Comparator section U4-B turns the transmitter bias switching (Vsw) on a few milliseconds later. This time delay eliminates a transmitter transient caused by the shifting DC levels when Q4 turns on. 'Catch' diode D7 rapidly turns off the bias supply when switching back to Receive to eliminate a similar transient.

The receiver's T-R switch function is provided by C1 and L1, which form a series-resonant circuit. Diodes D1-D4 limit during key-down and thereby restrict the signal levels presented to the receiver front-end during transmit. The double-diode configuration raises the network's intercept point with respect to W7EL's original configuration to improve IMD immunity.

Transmitter operation:

Audio from the computer soundcard is applied to the transmitter via J2 or J3. Q4 is switched on during transmit and allows soundcard audio to reach the amplifier stage (Q5 and associated components). Note that when Q4 is off during 'receive', DC bias is removed from Q5 and it is also non-conducting. The combination of Q4 and Q5 provide relatively high attenuation (>60 dB) of the soundcard audio during receive. This is necessary since the transmitter's DSB generator is running continuously- an audio signal applied to that stage's input would be plainly audible through the receiver. This situation would lead to soundcard feedback/distortion on receive without the presence of this muting function.

Q6 is an emitter follower which provide a 51-ohm source termination for diode-ring mixer U6. U6 is

driven by a signal from the 4.91 MHz LO, Colpitts oscillator Q7 and associated components. The output of mixer U6 is a suppressed-carrier double-sideband signal. After passing through the transmit IF filter comprising Y7-Y10 and related components, the signal has been reduced to a 4.91 MHz SSB signal.

U7 is an active mixer and is fed by the 4.91 MHz SSB signal and by the 11.98 MHz LO signal from Colpitts oscillator Q8 and associated components. The output of this mixer consists primarily of both the sum (16 MHz) and difference (7 MHz) of the frequencies applied to the mixer. Q9 is an emitter follower used to buffer the high-impedance output of the mixer. U8 is a Monolithic Microwave IC (MMIC) and provides approximately 12 dB of gain.

Because the output of mixer U7 has energy on a number of frequencies, bandpass filtering is required to clean up its spectrum. L8, L9 and associated capacitors form this filter, with input and output impedances of 50 ohms.

Q10 and associated components are the transmitter's driver stage. This stage is feedback-controlled by R50 for good linearity and operates class-A (always conducting). The output of this stage is L-network matched via L10 and C38 to the Power Amplifier (PA) base. D11 biases the PA base to the threshold of conduction, necessary for linear operation.

The PA stage (Q11) features a bifilar transformer (T2) at its collector. This provides a 1:4 impedance match, transforming the LO collector impedance at rated power to 50 ohms. L11-L13 and C40-C43 are a 7-pole lowpass filter used to remove harmonic content from the PA output waveform. The design with current FCC requirements for spurious emissions. All harmonics were down at least 52 dB. The largest spurious output is down 56 dB.

Output Indicator:

Diodes D13,D14 and associated components are a peak detector circuit and may be used to as an RF output indication. If you like, a 'T1-3/4' LED may be installed at TP2 on the board- this serves as a modulation indicator. This diode may alternatively be mounted remotely to the circuit board, since it's decoupled for RF frequencies by C122.

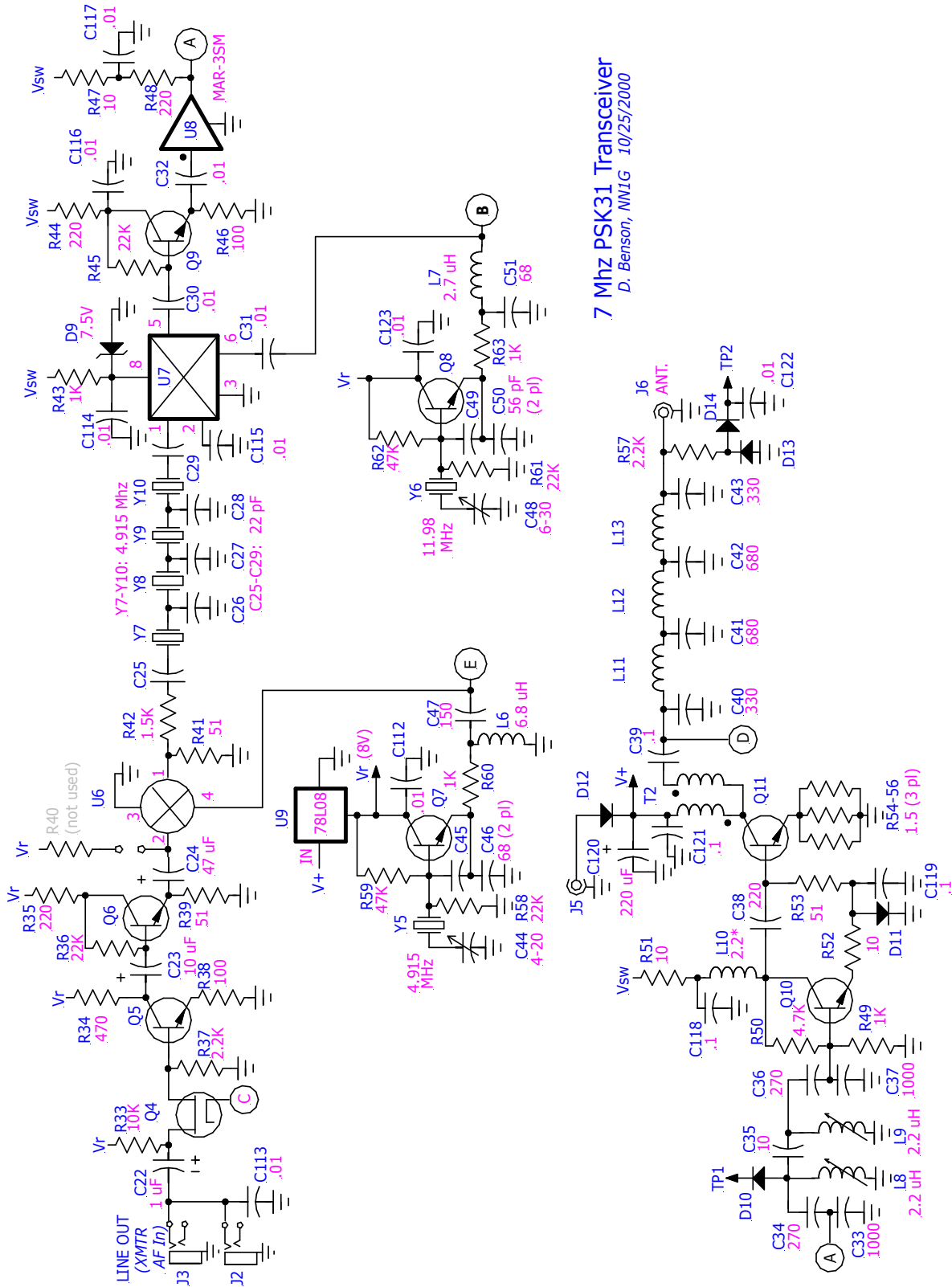

7 Mhz PSK31 Transceiver
D. Benson, NW1G 10/25/2000

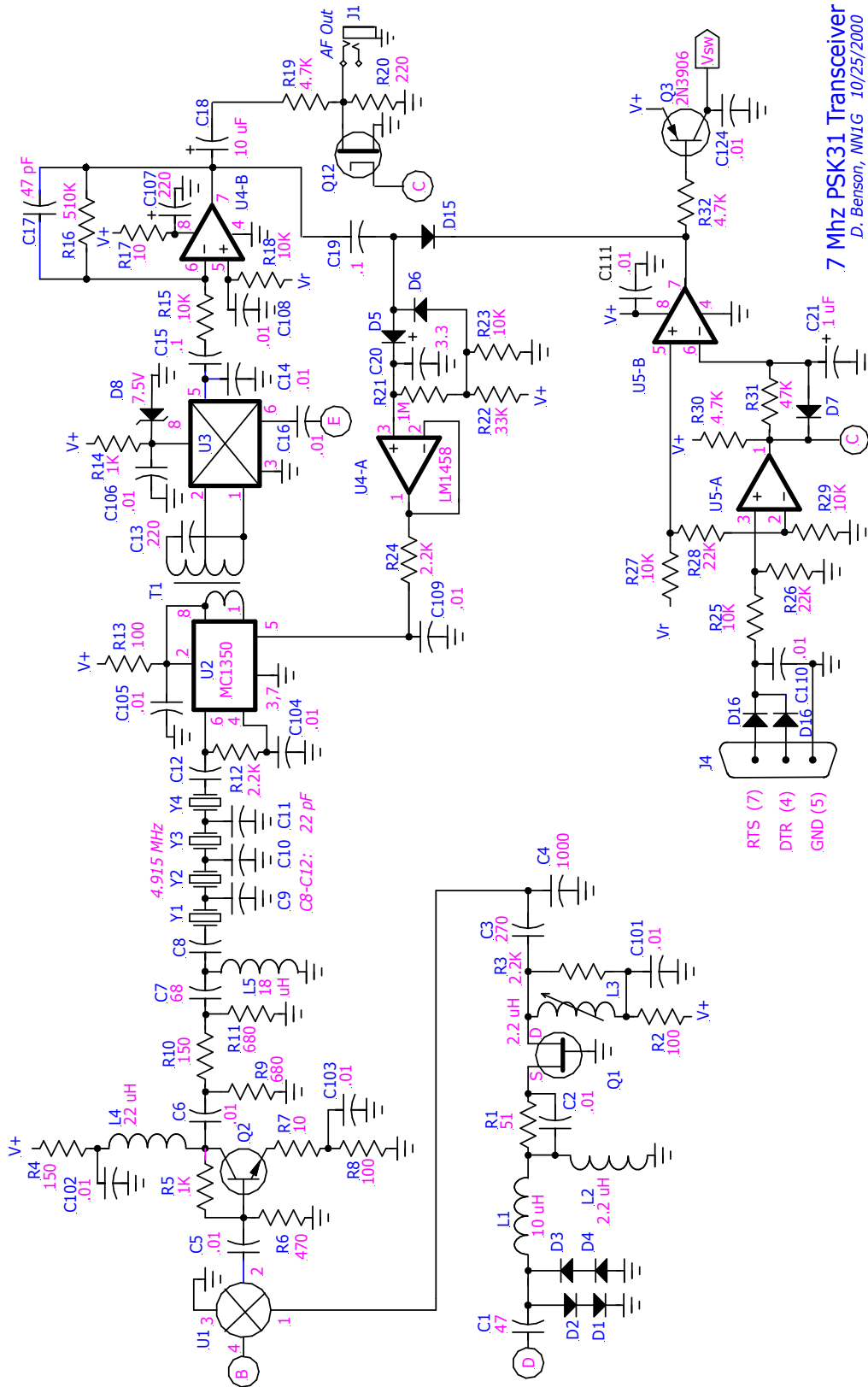

7 Mhz PSK31 Transceiver
D. Benson, MM1G 10/25/2000

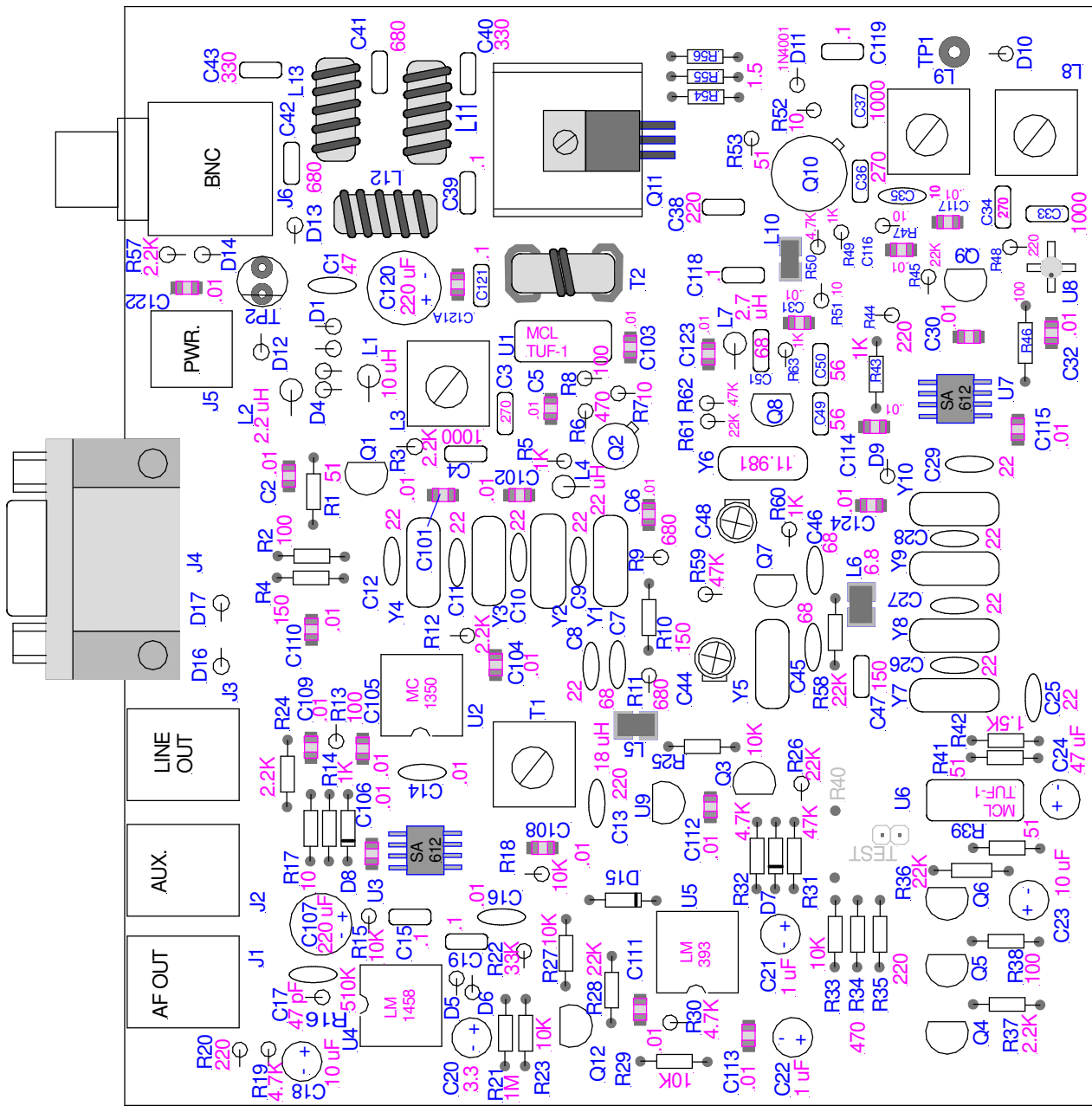

Building instructions:

All parts installed on the PC board should be fully seated unless otherwise noted in the assembly text..

Static-sensitive Components:

Components noted in bold in the assembly text are static-sensitive. The following general precautions apply:

- Keep these parts in the antistatic bag until you're ready to install them and handle them no more than necessary.
- Ideally, you've got a grounded-tip iron, but if not- After the part is installed on the board and before soldering, touch the iron tip to shack ground (if available) or to a PC-board ground point.
- Avoid placing these components on paper.
- Diode Installation:

Some of the diodes are bent for "upright" installation on the board. Installation polarity is as shown below. Be sure to note the orientation of the silkscreened circle on the board and install the diode body over this hole. The cathode (banded) end of the diode is oriented at the top. For diodes which are installed 'lying down', match the banded end to that shown on the silkscreen.

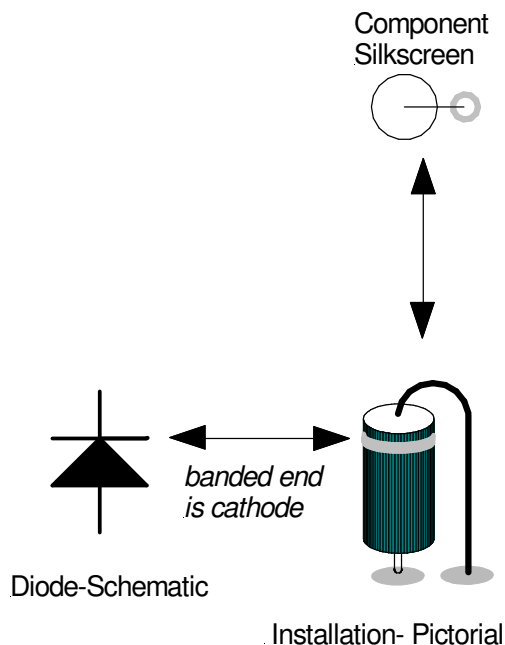

- Resistor installation:

Many resistors are likewise installed in 'hairpin' fashion. As with the diodes, try to match the mounting orientation shown on the drawing. (If mounted as shown you've got better troubleshooting access to circuit points from the top side of the board.) Orientation of color bands on resistors and other nonpolar devices is not critical.

- Installing IC sockets:

The "notch" or dot at one end should be oriented as shown in the pictorial drawings. Doublecheck orientation before soldering. A *suggestion*- solder down two opposite corners of each socket, and then go back and press a fingertip on the socket from underneath while reheating both connections in turn. You may then solder the remaining pads. This precaution ensures that the socket is well-seated on the PC board.

Recommended Assembly sequence:

I've specified the sequence detailed in the pages which follow, but there's nothing sacred about the order in which the board is populated. Some parts are best installed in a particular order, as noted within each group's instructions.

Directions for winding toroids are found within each group's assembly instructions.

'The Real Men's Corner:'

This is for the folks who don't read instructions- you know who you are! Be aware of the following:

- Crystals and the driver transistor (Q10) should be stood slightly (0.5 to 1mm) above the printed-circuit board to prevent shorts from case to ground.

Here's one other tip if you prefer to work only to the schematic and master pictorial:

Stuff only a few parts at a time (3-4 pieces). If you try to add too many parts at once between soldering operations, you may lose track and wind up with missing solder joints! Once you've stuffed the parts on the board, bend the protruding leads slightly outward to keep them in place while the board is inverted for soldering.

Group 2 Assembly:

Group 2 assembly installs the receiver 'back-end' circuitry.

- Install 3.5 mm (1/8") audio jacks at J1-J3.
- Install an 8-pin IC socket at U4. Match the 'notch' orientation as shown on the silkscreen.
- Install R20 (220Ω, red/red/brown).
- Install R19 (4.7K, ylw/violet/red).
- Install electrolytic cap C18 (10 uF). Observe the polarity marking on the device.
- Install R16 (510K, green/brn/ylw).
- Install R17 (10Ω, brown/blk/blk).
- Install R14 (1K, brown/blk /red).
- Install D8 (1N5236- from 'Zeners' envelope). Match the orientation of the banded end of the component to that of the silkscreen.
- Install C17 (47 pF disk cap).
- Install electrolytic cap C107 (220 uF). Observe the polarity marking on the device.
- Install C14 (.01 uF disk cap), '103'''
- Install C15 and C19 (.1 uF monolithic caps), '104'
- Install R15 (10K, brown/blk /orange).
- Install C16 (.01 uF disk cap).
- Install diodes D5 and D6 (1N4148). Observe the installation polarity as shown on the silkscreen.
- Install electrolytic cap C20 (3.3 uF). Observe the installation polarity as shown on the silkscreen.
- Install R21 (1 Megohm, brn/blk/green.)
- Install R23 (10K, brn/blk/orange).
- Install R22 (33K, orange/org/org).

- Install R18 ((10K, brn/blk/orange).
- Install C13 (220 pF disk cap).
- Install D15 (1N4148). Match the orientation of the banded end of the component to that of the silkscreen.
- Install IF transformer T1. **Caution:** Ensure that you install the transformer marked '42IF123' in this location. *The slug in this transformer is colored green.*
- Install Q12 (2N7000- from antistatic bag). Match the orientation of the flat side of the component to that of the silkscreen. **This part is static-sensitive.**

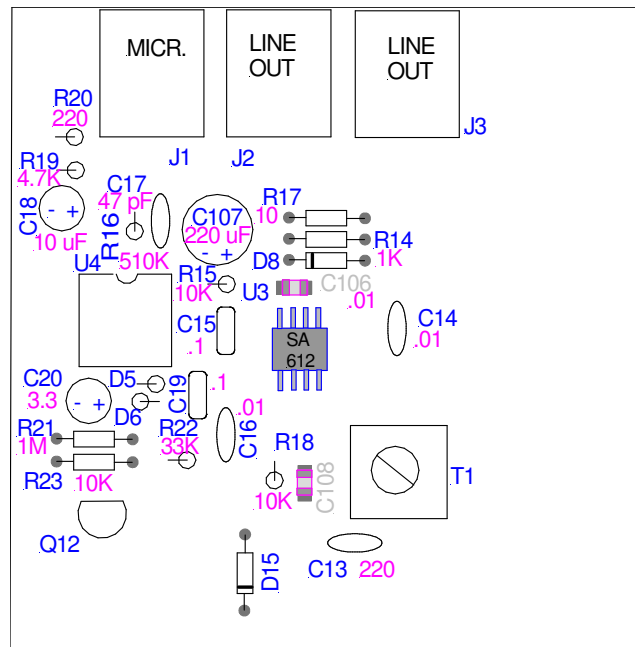

Group 3 Assembly:

Group 3 assembly installs the 4.9 MHz and 11.98 MHz local oscillators.

- Install surface-mount inductor L6 (6.8 uH, from envelope). *Note: the inductor itself is inside a black plastic carrier. Pre-tin the inductor pads on the PC board sparingly with solder before installing the part.* Place this component on the two pad locations and restrain carefully in place with tweezers. Tack one end down with the soldering iron, solder the other end sparingly, and retouch the end originally tacked down. **Good component alignment is important to ensure that there are no short-circuits- check your work carefully for solder bridges.**
- Install trimmer capacitor C44 (**RED**). Be sure to orient the 'flat' side of the capacitor body as shown on the pictorial and silkscreen.
- Install trimmer capacitor C48 (**GREEN**). Be sure to orient the 'flat' side of the capacitor body as shown on the pictorial and silkscreen.
- Install one of the 4.915 MHz crystals at Y5. Install this component slightly above the board (0.5 to 1 mm) to prevent the case from shorting to board traces. *This is best accomplished by installing and soldering the crystal in place and then retouching the connection while pulling gently on the component to lift it slightly.*
- Install R59 (47K, yellow/violet/org).
- Install R58 (22K, red/red/org).
- Install R60 (1K, brown/blk/red).
- Install disk caps C45 and C46 (68 pF).
- Install monolithic cap C47 (150 pF).

***Note:** these components are somewhat fragile. To spread the lead spacing to match the 0.2" (5mm) spacing on the pads, grasp the capacitor body between thumb and forefinger. Spread the wire leads apart outward, taking care not to bend the leads right at the capacitor body. The wire leads may then be re-bent a few mm away from the capacitor*

body to re-form them at the correct parallel spacing.

- Install transistor Q7 (2N4401, from antistatic bag). Match the orientation of the flat side of the component to that of the silkscreen.
- Install the 11.98 MHz crystal at Y6. Provide height clearance as noted previously for Y5 for this and all remaining crystal installations.
- Install R61 (22K, red/red/org).
- Install R62 (47K, yellow/violet/org).
- Install R63 (1K, brown/blk/red).
- Install C51 (68 pF monolithic cap).
- Install monolithic caps C49 and C50 (56 pF).
- Install transistor Q8 (2N4401, from antistatic bag). Match the orientation of the flat side of the component to that of the silkscreen.
- Install L7 (2.7 uH RF Choke, red/violet/gold). Avoid bending the 'hairpin' component lead too sharply where it exits the component body.

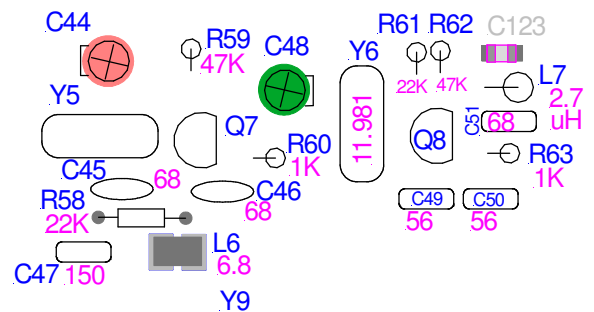

Group 4 Assembly:

Group 4 assembly installs the receiver IF amp, crystal filter and mixer post-amp.

- Install R24 (2.2K, red/red/red).
- Install R13 (100Ω, brown/blk/brown).
- Install R4 (150Ω, brown/green/brown).
- Install an 8-pin IC socket at U2. Match the 'notch' orientation as shown on the silkscreen.
- Install R12 (2.2K, red/red/red).
- Install surface-mount inductor L5 (18 uH, from envelope). See the discussion of the previous page for installation cautions.
- Install C7 (68 pF disk cap).
- Install C8 through C12 (22 pF ceramic disk caps).
- Install four of the 4.915 MHz crystals at Y1-Y4.
- Install R10 (150Ω, brown/green/brown).
- Install R9 and R11 (680Ω, blue/gry/brown).
- Install L4 (22 uH RF choke, (red/ red/black)
- Install R5 (1K, brn/black/red).
- Install R6 (470Ω, yellow/violet/brown).
- Install R7 (10Ω, brn/black/black).
- Install R8 (100Ω, brn/black/brown)
- Install Q2 (2N2222, small metal-can transistor). Align the tab on the device rim to match that of the silkscreen.

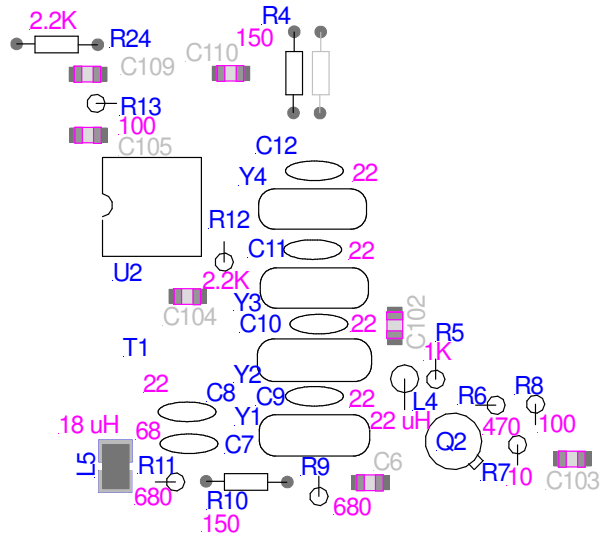
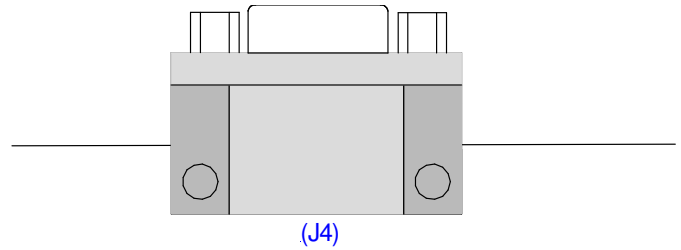

Group 5 Assembly:

Group 5 assembly installs the first mixer and preamp.

- Install R2 (100Ω, brown/blk/brown).
- Install R1 (51Ω, green/brown/black).
- Install R3 (2.2K, red/red/red).
- Install C4 (1000 pF monolithic cap, '102J')
- Install C3 (270 pF monolithic cap, '271J')
- Install L3, Toko shielded Inductor, 'TKANS 9447'
- Install D1 through D4 (1N4148s). Match the installation polarities as shown on the silkscreen and on as shown on the figure on this page.
- Install L1 (10 uH RF choke, (brown./blk/blk).
- Install L2 (2.2 uH RF choke, (red/red/gold).
- Install C1 (47 pF disk cap).
- Install transistor Q1 (J309/J310, from antistatic bag). Match the orientation of the flat side of the component to that of the silkscreen.
- Install Mixer U1 (MCL TUF-1 or TFM-2) , from antistatic bag). **Be sure that the part labeling is oriented as shown on the figure on this page and that the part correctly overlaps the silkscreened outline on the board.**

Caution: *This component should be spaced slightly above the board. Solder only 1 of the 4 pins into place initially. Adjust component spacing above the board while briefly reheating this connection, then solder the remaining connections.*

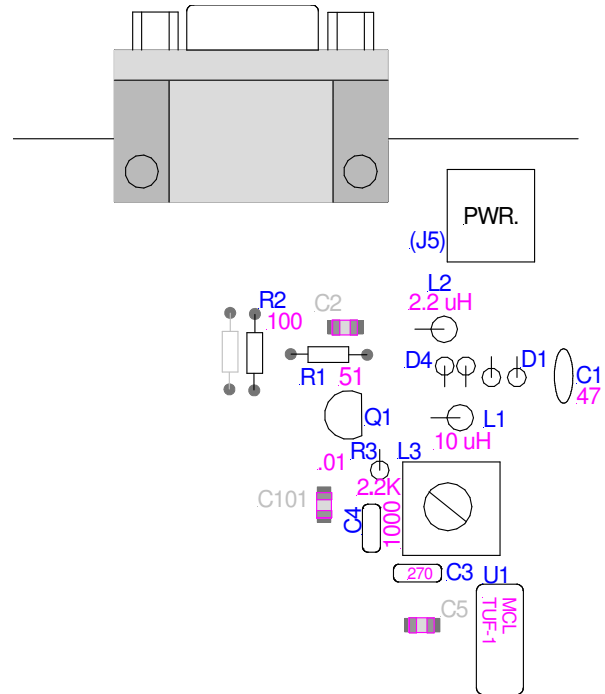

Group 6 Assembly:

Group 6 assembly installs the audio switch and transmit first mixer.

- Install C22 (1 uF electrolytic cap). Observe the installation polarity as shown on the silkscreen.
- Install R33 (10K, brown/blk/orange).
- Install R34 (470Ω, yellow/violet/brown).
- Install R35 (220Ω, red/red//brown).
- Install R36 (22K, red/red/orange).
- Install R37 (2.2K, red/red/red).
- Install R38 (100Ω, brown/blk/brown).
- Install R39 and R41 (51Ω, green/brn/black).
- Install C23 (10 uF electrolytic cap). Observe the installation polarity as shown on the silkscreen.

Component outlines "R40" and "TEST" are unused-do not populate these locations.

- Install C24 (47 uF electrolytic cap). Observe the installation polarity as shown on the silkscreen.
- Install Q4 (2N7000- from antistatic bag). Match the orientation of the flat side of the component to that of the silkscreen. **This part is static-sensitive.**
- Install Q5 and Q6 (2N4401- from antistatic bag). Match the orientation of the flat side of the components to that of the silkscreen
- Install Mixer U6 (MCL TUF-1 or TFM-2), from antistatic bag). **Be sure that the part labeling is oriented as shown on the figure on this page and that the part correctly overlaps the silkscreened outline on the board.**

Note: observe the component spacing precaution as with U1 on the previous page.

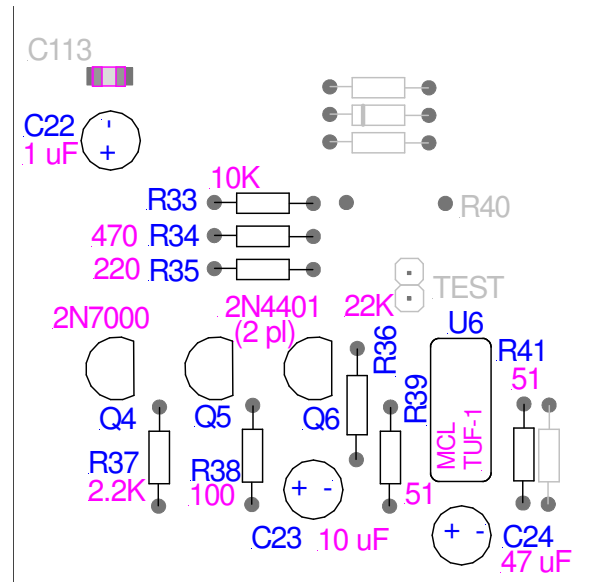

Group 7 Assembly:

Group 7 assembly installs the transmitter IF filter and second mixer stages.

- Install R42 (1.5K, brown/green/red).
- Install C25 through C29 (22 pF disk caps).
- Install the remaining four 4.915 MHz crystals at Y7-Y10.
- Install R43 (1K, brown/blk/red).
- Install D9 (1N5236- from 'Zeners' envelope). Match the orientation of the banded end of the component to that of the silkscreen.
- Install R44 (220Ω, red/red/brown).
- Install R45 (22K, red/red/orange).
- Install R46 (100Ω, brn/black/brown).
- Install Q9 (MPSH10, from antistatic bag). Match the orientation of the flat side of the component to that of the silkscreen.

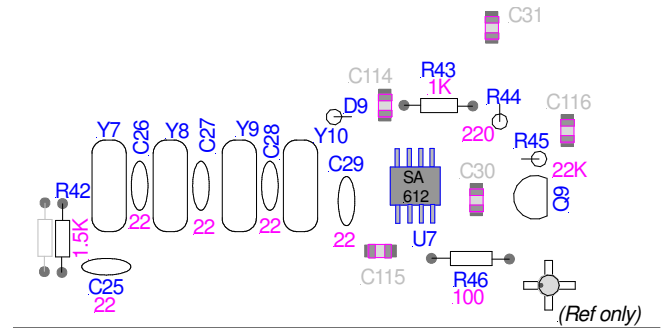

Group 8 Assembly:

Group 8 assembly installs the transmitter bandpass filter and driver stages.

- Install R47 (10Ω, brn,black,black).
- Install R48 (220Ω, red,,red,brown).
- Install C33 (1000 pF monolithic cap, '102J').
- Install C34 (270 pF monolithic cap, '271J').
- Install C35 (10 pF disk cap).
- Install C36 (270 pF monolithic cap, '271J').
- Install C37 (1000 pF monolithic cap, '102J').
- Install L10 (2.2 uH SMT inductor, from the 'L10' envelope)
- Install L8 and L9 (remaining two Toko tunable inductors, 'TKANS 9447').
- Install R49 (1K, brown/blk/red).
- Install R50 (4.7K, yellow/violet/red). **Note: there is no silkscreened reference designator for this component.** Note its placement carefully with respect to nearby silkscreened component outlines before installing and soldering.
- Install R51 and R52 (10Ω, brown/blk/black).
- Install C118 and C119 (.1 uF monolithic cap, '104')
- Install D10 (1N4148). Match the orientation of the banded end of the diode with that of the silkscreen.
- Install D11 (1N4001, power diode). Observe the installation polarity as shown on the silkscreen.
- Install Q10 (2N2219, from antistatic bag). Space this component 0.5 to 1mm above the board surface to prevent shorts to the transistor case. Observe the component's tab orientation as shown on the silkscreen.

- Install C38 (220 pF monolithic cap, '221J').
- Install R53 (51Ω, green/brn/black).

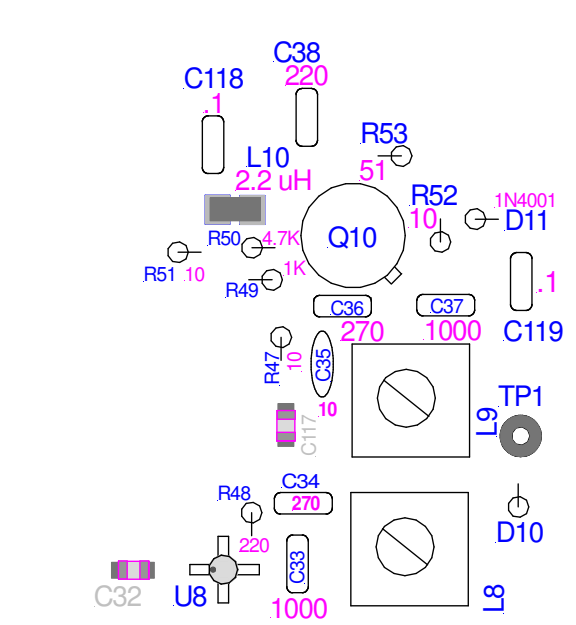

Group 9 Assembly:

Group 9 assembly installs the transmitter final amplifier and lowpass filter.

- Using a 16" (40 cm) length of magnet wire supplied with the kit , wind 18 turns on one of the 1/2" (1.2 cm) diameter **yellow** toroids. After passing the wire through the center hole each time, pull it snug against the toroid as you proceed. Make sure that each turn lays flat on the core- 'crossed' or scramble-wound turns must be avoided.
- Doublecheck the turns count, adjust the spacing between turns for a uniform appearance.
- Trim the excess wire length to 3/8" (1cm) and strip the insulation off the lead ends using a sharp knife. This needs to be fairly thorough- rotate the core as you scrape until the bare copper is visible around the lead. Install at L11 and solder.
- Using a second 16" wire length and yellow toroid , repeat the above sequence and install this 18-turn toroid at L13 (nearest to board corner).
- Using a third 16" wire length and the last yellow toroid, wind 19 turns and install at L12 (*mounts at right angles to the two toroids already installed*).
- Find the 5" (12 cm) length of heavy wire bundle supplied with the kit. Nick the insulation jacket slightly to expose one or more individual wires- pull these out of the jacket (discard the jacket).
- Select any 2 of the 4 wires and pass both through the hole in the toroid.
- Wrap this wire-pair snugly around the toroid for one complete turn. It should look like this:

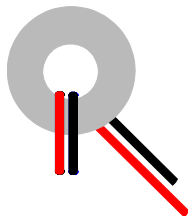

- Proceed to thread the wire pair through the hole again and draw it snug . Repeat this threading operation twice more (a total of 4 wire-pair turns through the hole in all).

Caution:

The wires must not cross over each other as they are laid down on the core (i.e., there are no 'twists' built into the wire. If (color 1) is on the leading edge in the direction you're winding, it must continue on the leading edge for all 4 turns.

'Clockwise' and 'counterclockwise' winding senses are non-critical- either one is fine.

Here's what the result looks like:

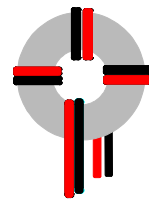

Note the way the color-pairs are arranged as they proceed around the core.

- As you look through the toroid hole (as shown above, confirm that the 2 (first color) leads protruding are on the left and the 2 (other color) are on the right.
- Cut the protruding leads to a length of 1/2", strip these with the wirestripping tool and install at **T2**. Doublecheck the insulation colors before soldering this component down.-
- Install C40 and C43 (330 pF monolithic caps , '331J').
- Install C41 and C42 (680 pF monolithic caps , '681J').

- ❑ Install C39 and C121 (.1 uF monolithic caps, '104').
- ❑ Install R57 (2.2K, red/red/red).
- ❑ Install D13 and D14 (1N4148). Observe the installation polarity as shown on the silkscreen.
- ❑ Install the BNC connector.
- ❑ Install R54 through R56 (1.5Ω, brown/green/gold).
- ❑ Using a small screwdriver blade (or 8-10d common nail) as a 'form', bend the 3 leads downward at a 90° angle as shown, immediately outboard of the wide portion of the leads. **Take care to ensure the resulting bent leads are uniformly distant from the transistor body.**

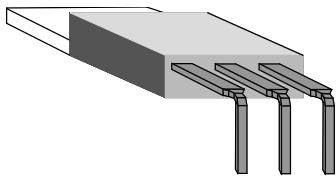

- ❑ Place the heat sink on the board, insert Q11's three leads into the corresponding holes in the board. (*Do not solder yet.*) Place the 1/4" (6.3mm) machine screw through the hole in the transistor tab and through the heatsink and printed circuit board. Secure in place with a nylon nut. Make sure that the heat sink is aligned parallel with the board before tightening the nut. **Tighten cautiously- the nylon nut threads will strip at the torque typically used for steel hardware.** Solder Q11's leads into place.

Caution: do not substitute a metallic nut here!

You may find it easier to pin the transistor and heat sink together with the machine screw, using a fingertip to hold the screw

down while inserting the transistor leads into the board.

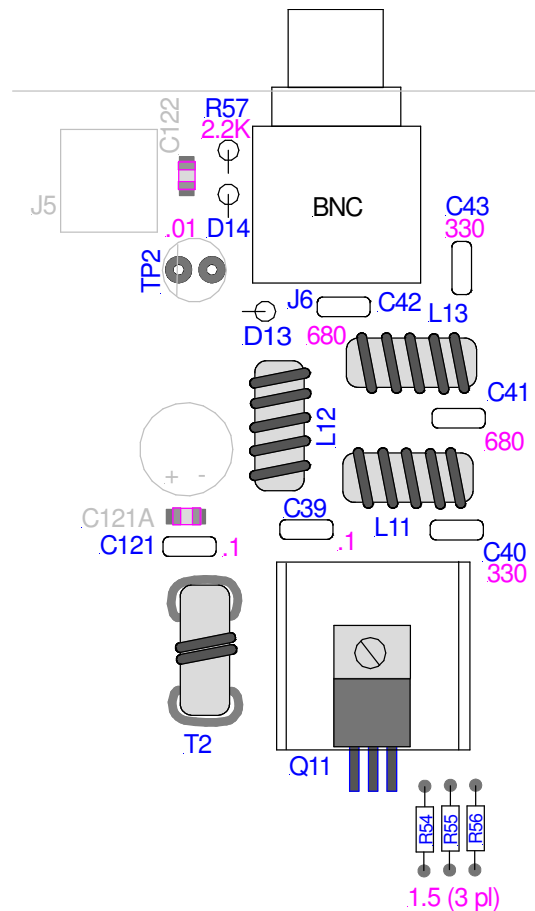

That's it- board assembly is complete!

CLEAN UP YOUR ACT! Before you proceed to checkout, grab some cotton swabs and use acetone (nail polish remover) to remove solder flux from the underside of the PC board. The result is a much cleaner appearance once you've completed this step. **Use caution to avoid getting acetone on the top side of the boards- some of the plastic items may be softened by contact with it.**

Hooking Up:

The figure below shows the interconnect between the PSK-40 board and the outside world (more on alignment later)

Before the "Smoke Test":

□ Inspect your work to ensure there are no solder bridges or unsoldered joints. Check to see that the ICs are mounted in their proper orientations, or install them if you haven't already done so (*see p.10 for placement*).

PSK-40 Mechanical Details

The board itself may be mounted in an enclosure at the board's four corners, using #4 machine screw hardware. #4 spacers should be used to separate the PC board from the enclosure by 3/16" or more. (#4 hex nuts are an acceptable substitute for spacers.)

Enclosures may be found in a variety of styles. Radio Shack offers several types of metallic

enclosures. I'd especially recommend Hosfelt Electronics, Inc., who carry enclosures offered by a number of companies. There's no minimum order, and they can be reached at [800] 524-6464 for a catalog. Ten-Tec also offers a complete line of enclosures, and they support small orders as well! Call [800] 231-8842 for a free brochure.

The enclosure option for this transceiver is a Lansing 'Micropak' CT1-series enclosure with a companion custom-punched end panel. The board size is tailored to fit the enclosure side-rail slots and the custom panel bolts to the DB-9 (serial port) connect for rigidity. Information on this enclosure may be found at:

http://smallwonderlabs.com/swl_psk31.html

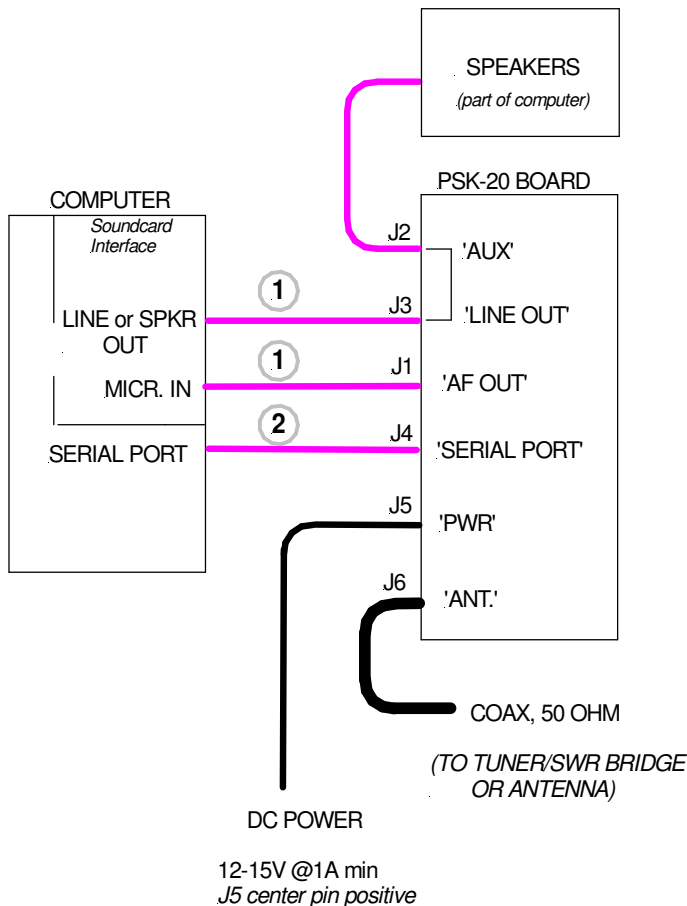

CABLE DESCRIPTION:

- ① 3.5mm stereo (3-cond) to 3.5mm stereo (3-cond)
Radio Shack # 42-2387
(2 required)
- ② DB-9 (Serial port) Male to DB-9 female Cable
Radio Shack # 26-117
or Jameco (800-831-4242) #25700

Alignment Instructions

- If you have not already done so, install all DIP ICs in their respective sockets. *It may be helpful to bend each row of IC leads inward by pressing it gently on a table surface- this will ease installation.* Doublecheck the IC locations and orientation before proceeding.
- Wire the DC power plug with the 2' (60cm) length of 2-conductor wire supplied. **The lead with the identifying stripe should be connected to the center conductor of the plug.** (The PSK-40 is protected against reverse polarity mishaps.)

Receiver Alignment:

- Connect a 3.5mm (1/8") 3-conductor shielded cable between your computer soundcard Microphone input and the PSK-40's AF OUT jack (J1).
- If you have not already done so, download the DigiPan application software. Here is a direct link to the software:
<http://mywebpages.comcast.net/heller/digipan/> *Version 1.2 is current*

Here is a link to a site with additional PSK31 information which you may find useful:
<http://psk31.com>

The "Software" link on this page will take you to the DigiPan software download site.
- Open the DigiPan application and click on the Configure menu option, select "Spectrum Drive". Make sure "Microphone" is checked and advance the microphone gain to maximum (see Frequently Asked Questions', p.26, for details).
- Install the power plug at J5 and connect DC power (12-15V).

The area on your computer screen below DigiPan's frequency scale has been black. It should now contain blue 'sparkles' once power is applied.
- Connect your computer soundcard LINE OUT or SPKR OUT to the PSK-40's J3

connector with a 3.5mm (1/8") 3-conductor cable. Connect your computer speaker cable to the PSK-40's J2 connector. *J2 and J3 are in parallel and permit use of the soundcard for other applications without repeated plugging and unplugging of cables.*

- Using a small slot screwdriver, adjust transformer T1 for maximum audio to the speakers. *Note: If you have an antenna connected already, AGC action may make it difficult to get a clean peak- remove the antenna for this step.*
- On the DigiPan menu bar, click on 'CONFIGURE', and select 'BAND'. In the dialog box, click on 40M and verify that the settings are as follows: '7070' for 'Start Frequency, KHz' and 'USB'. Click 'OK ' to return to the main menu.
- Adjust trimmer capacitor C44 (above Y5) with a small slot screwdriver to center the noise picture in the leftmost 4 KHz (7070-7074) portion of DigiPan's panoramic display window. *When centered, the dark edges of the display within that 4 KHz range should appear roughly symmetrical.*

The left edge of the screen (in full-screen mode) corresponds to 7070 KHz
- Connect a 50-ohm nominal antenna to J6. You should now see additional noise content and very likely, amateur signals will now be present on the display. Using the plastic tuning tool, adjust inductor L3 for maximum audio to the speakers.

Frequency Alignment:

- Using the computer mouse, click the DigiPan display point immediately below the '7072' frequency tick mark. The 'diamond' symbol will jump to that location.
- Using a 'big rig', transmit a CW signal on 7072.0 (into a dummy load, please). A bright signal line should appear somewhere within the frequency display. Using a small slot screwdriver, adjust C48 (left of Y6) until the bright line's position is lined up with the '7072' tick mark.

Receiver Alignment is now complete.

- To copy PSK31 signals, click the mouse cursor on the center of the signals and copy should appear shortly thereafter in the upper text window.
- *It may be necessary to readjust the soundcard microphone gain settings to prevent overloading the soundcard.*

Transmitter Alignment:

Caution: *You must perform the receiver alignment before aligning the transmitter!*

- Remove DC power from the PSK-40, connect the serial port cable (see 'Hooking Up'), and reinstall DC power.
- Remove the antenna from J6 and connect a dummy load in its place.
- Click on the DigiPan 'Configure' menu option and select 'Transmitter drive'. Set the soundcard 'Wave' or 'All Waves', etc., slider level to maximum. Set the slider level on the master volume slider to half- scale and close that dialog box.
- Click on 'TX' on the DigiPan menu bar. Using a multimeter set on 'DC Volts', (return lead to board ground) verify that the voltage on the case of Q10 (TX driver) jumps up to ~12V. This confirms that the transmitter bias is being switched on by the serial port connection. *If the PA is getting hot due to prolonged key-downs, you may return to receive by clicking on 'RX' on the DigiPan menu bar.*

No Joy?

Make sure that DigiPan is configured to the correct serial port setting. Click on 'Configure' on DigiPan's menu bar and select 'Serial Port'. Experiment with the COM port selection until you find the one which works (typically COM1 or COM2). The serial port signal (RTS) should be at approximately -10V during 'Receive' and +10V during 'Transmit'. At least one of the 'RTS as PTT' or 'DTR...' buttons must be checked- the PSK-40 responds to either one.

- Connect the multimeter , (return lead to board ground) to TP1 in the lower right corner of the board. Using the plastic tuning tool, adjust inductor L8 for a maximum meter indication.
- Connect the multimeter , (return lead to board ground) to TP2's rightmost pad, left of the BNC jack. Adjust inductor L9 for maximum meter indication.
- Adjust the master volume slider (Speaker icon) for a DC voltage reading of 5 to 8 volts at TP2.
- Readjust inductor L8s and L9 - in that order- for maximum indication.

Note: L8, L9 adjustment procedure may alternatively be performed using a wattmeter and dummy load:

Adjust L8, L9 alternately for max output on wattmeter. Reduce audio output level in DigiPan as necessary to keep wattmeter at less than one watt.

Transmitter Operational Adjustment:

If you have a wattmeter available:

Select the DigiPan 'Mode' menu option and adjust the master volume slider (lower right corner of screen-speaker icon) for 3 Watts of indicated power output. Click 'OK' to stop transmitting. In actual operation, as you type on the computer keyboard, you should see the output power flicker upward by about 25%. *There is a brief burst of full-power carrier from DigiPan at the end of each transmission, this meter indication will be the same as for the 'tune' power level.*

If no wattmeter:

Install a T1-3/4 LED at TP2. *The 'flat' edge of the LED body should face to the left.* When transmitting, this diode should glow steadily when idling and will flicker noticeably brighter when you're typing. Adjust the master volume slider as needed to achieve this indication. *This diode may be installed remotely on a front panel to serve as a rough power indication.*

If you have an oscilloscope:

Click on TX and set the output envelope just below the level where distortion becomes noticeable. This will be on the order of 40V p-p, depending on power supply voltage.

Troubleshooting the PSK-40:

The "bugs" you're most likely to encounter often turn out to be caused by the simplest of problems. If your "PSK-40" doesn't play, here are some general troubleshooting guidelines.

"It works better plugged in!"

We've all heard that expression before, but unfortunately it's true. Ensure that DC power is getting to the PSK-40. A board with no voltage anywhere probably isn't getting power.

General guidelines:

Check once more for solder bridges and missing solder joints. Probing a suspect section of the circuitry with a fingertip or insulated tool will sometimes bring a stubborn circuit to life- if so, check again for a bad connection!

Of the returns I see, about 85% of the problems are caused by cold solder joints, 5% by solder bridges and 5% due to incorrect resistor installation. That leaves only 5% for all the other problems put together. Enough said!

- Ensure that the ICs are installed in the correct location and with the right orientation.
- Likewise ensure that the transistors and all diodes are installed with the correct orientation.

Receiver troubleshooting- general:

Starting at the AF amp (U4-B) input, probe with a small screwdriver or similar metal tool- there should be some indication of a signal on the computer's panoramic display. Repeat this probing, moving back 'upstream' (toward the receiver input) through the signal path. If there's a stage where the chain is broken and there's no longer any response, chances are good that's where a problem is!

Transmitter troubleshooting- general:

If an RF signal is getting to the transmitter final stage, but there's no apparent output, check the following:

- measure DC continuity with an ohmmeter across R54-R56 to ground. This reading should be approximately 0.5Ω.

Doublecheck the installation of T2- a miswire here assures there'll be virtually no RF output!

If you don't turn up anything with the above steps, see the troubleshooting information at:

http://smallwonderlabs.com/swl_psk31.html

- The figure below illustrates IC pinout. The "pin 1 at lower left" convention applies to all Dual-Inline-Package (DIP) ICs.

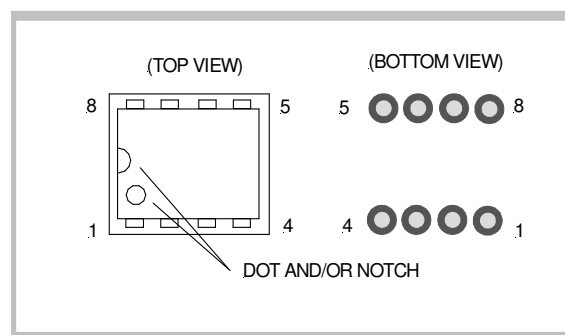

"Strange but True"- In general, the ICs themselves shouldn't be prime suspects during the troubleshooting process. Despite their complexity, they're very reliable, and I've had to replace these parts at the rate of only 1 for every thousand or so shipped!

- If you're still stumped, contact me for further technical support:

Dave Benson, K1SWL
32 Mountain Road
Colchester, CT 06415
Tel: 860-537-8031
e-mail: dave@smallwonderlabs.com

Troubleshooting is available for a flat \$40 fee. The unit will be returned to you in working condition and will include a troubleshooting report. Contact me for shipping instructions- this work is currently done offsite.

FREQUENTLY-ASKED QUESTIONS:

- **How do I adjust the soundcard settings?**

With DigiPan already opened, click on Configure and select 'Spectrum drive'- the following appears

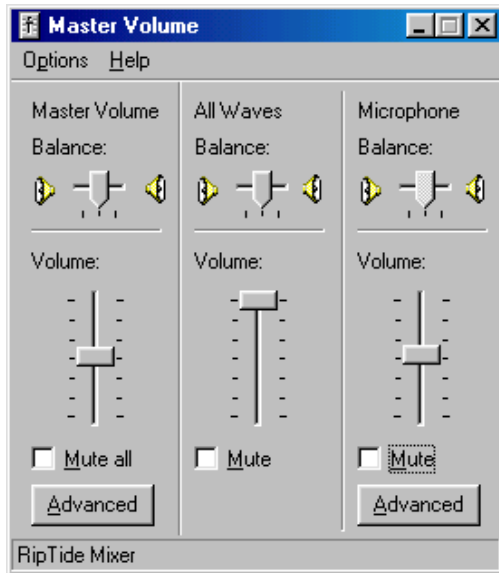

The master volume setting affects drive to the transmitter and may also be accessed by clicking on the speaker icon in on the Windows task bar (lower edge of screen, right end.) Double-clicking this icon brings up the dialog box above.

You may use the slider under "Microphone" to set receiver levels.

You may single-click on the speaker icon to get just the master volume slider. This control adjusts the transmitter drive levels. *Try starting with Half-scale.*

- **I've clicked on a good signal but nothing's showing up!**

There are several possible causes.

- Make sure it's a PSK31 signal- it should have the typical 'railroad tracks ' appearance on the display. If it's just a pair of vertical lines, it's an 'idling' pattern and there's no information being sent.
- If the signal is badly smeared by propagation conditions, the phase information may be lost - PSK31 is susceptible to polar (auroral) flutter.

- DigiPan has an adjustable squelch threshold. Click on the 'SET' menu choice at the top of DigiPan and select "Squelch Threshold"- check to ensure the threshold slider isn't set too high for the signal you've selected and adjust if needed.

- **What is the 'IMD' indication and how it used?**

Whenever DigiPan detects an idling pattern on a received signal, it calculates an intermod figure by measuring sideband energy at the frequencies which are generated by a overdriven transmitter. Note: your QRP signal may be near the noise floor to begin with- an IMD reading obtained from operators you're in QSO with may not be meaningful under these conditions

- **Why didn't you use VOX? - it would have saved a cable!**

- Windows makes assorted noises when you change settings- these are prone to turning VOX on.

- When DigiPan is not in use, your soundcard may be used for other applications. If the rig is left powered, you don't want your favorite CD going out on the air!